



RELAY-MINI

Dry Contact Card

User's Manual

Product Introduction



RELAY-MINI card

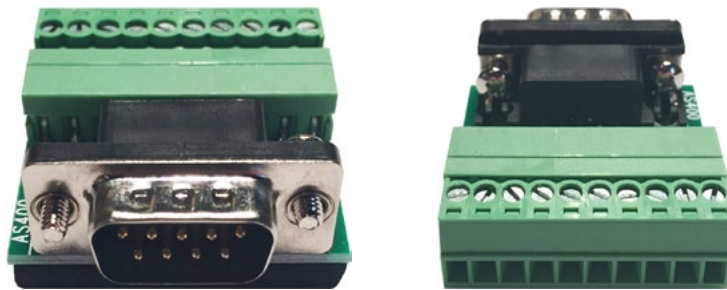

Included terminal block accessory, front and rear view

The RELAY-MINI provides Form C relay dry contact closures for remote monitoring of your UPS. For versatility, the RELAY-MINI is capable of selecting Active Open or Active Closed via jumper setting. It also provides for DB9 or terminal block output connections. Suitable applications for this card are listed below:

- IBM Server, Personal PC & Workstations equipment
- Auto-controlled industrial equipment & communication applications

Installation

Step 1: Remove the cover of Intelligent Slot on the rear panel of the UPS, saving the two screws.



Step 2: Insert RELAY-MINI into Intelligent Slot. Ensure sides of card slide into rails of the card slot.



Step 3: The faceplate of the RELAY-MINI should be against the rear panel. Use a screwdriver to secure the RELAY-MINI to the UPS chassis with the two screws saved in Step 1.



Step 4: Use a 9-pin communication cable to connect monitoring equipment to DB9 or stripped wires to connect to screw terminals, implementing the remote monitoring and control.



Specifications

Internal Circuit of DB9 port

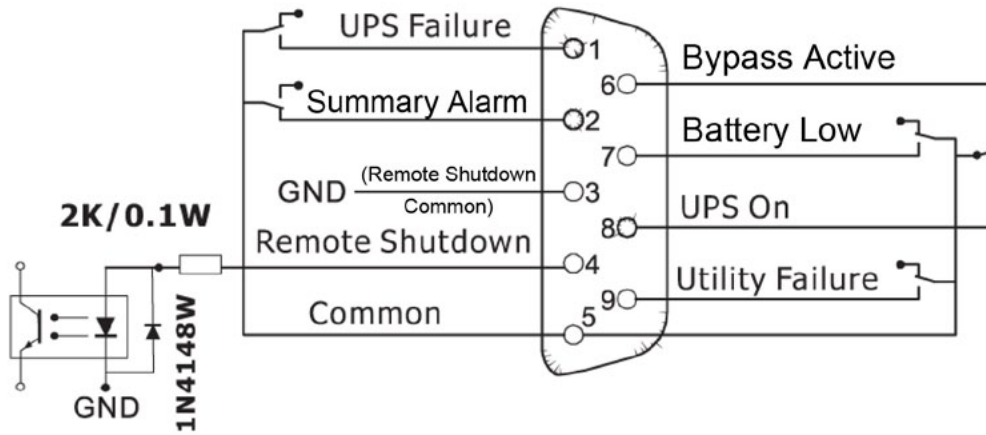

DP9 Pin Assignment

Pin Assignment	Function	I/O
Pin 1	UPS Failure	Output
Pin 2	UPS Summary Alarm	Output
Pin 3	GND (Common for Pin 4)	Power Ground
Pin 4	Remote Shutdown	Input
Pin 5	Common for relays	Power Supply
Pin 6	Bypass Active	Output
Pin 7	Battery Low	Output
Pin 8	UPS On	Output
Pin 9	Utility Failure	Output

All relays are rated at 24V, 1A. The shutdown pin (pin4 & pin3) only accepts 3-10s high level signal to perform the UPS shutdown. Signal limited to 6V, 6mA. Otherwise, it's necessary to add one resistor within DC current limitation in the serial loop of Remote Shutdown. (e.g. 2K resistor with at least 0.1W rating power). Refer to the diagrams in Application.

Relay Function Description

Active Closed Status	Active Open Status	Reason
Pin 1 & Pin 5 closed	Pin 1 & Pin 5 open	UPS internal failure
Pin 2 & Pin 5 closed	Pin 2 & Pin 5 open	UPS failure, utility failure, low battery, bypass active
Pin 6 & Pin 5 closed	Pin 6 & Pin 5 open	Bypass active
Pin 7 & Pin 5 closed	Pin 7 & Pin 5 open	Battery voltage is low
Pin 8 & Pin 5 closed	Pin 8 & Pin 5 open	UPS is in online/double conversion mode
Pin 9 & Pin 5 closed	Pin 9 & Pin 5 open	Utility failure/on battery mode

Application

Below shows the circuit of basic application to implement monitoring and control.

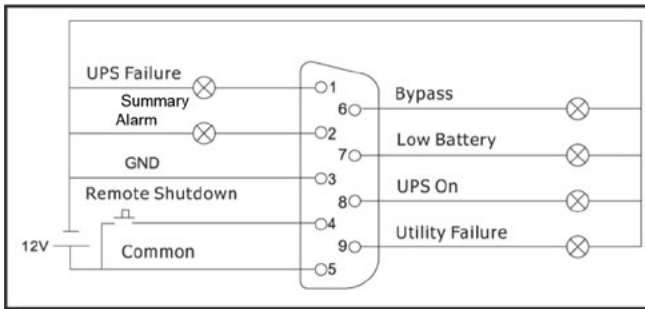

User Interface for 12V

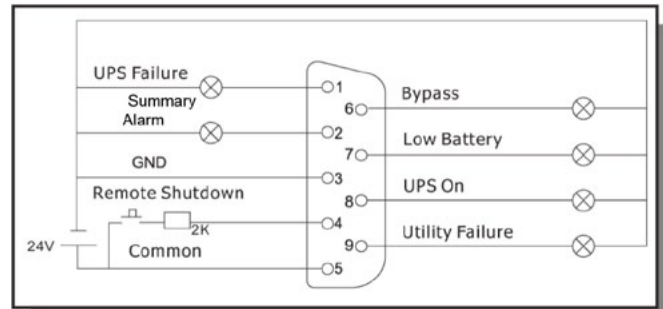

User Interface for 24V

Internal Logic Connection

The IC controller of the card controls the actions of 5 relays depending on the UPS status. Active Closed terminal and Active Open terminal of each relay connect to Pin 3 and Pin 1 of a 3-pin connector respectively. Pin 2 of the 3-pin connector connects to the signal pin of the DB9 interface connector. The 2-pin jumper can be plugged to the 3-pin connector to either connect Pin 1 & Pin 2 (Active Closed) or Pin 3 & Pin 2 (Active Open).

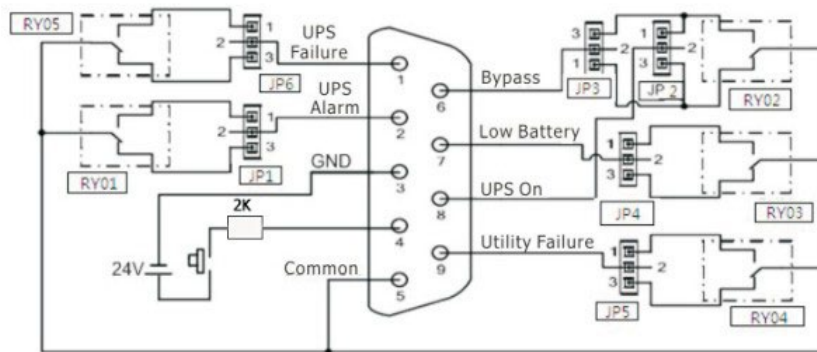

Pin definition and internal logical connection

Accordingly, if Pin 1 connects with Pin 2 via the jumper, the status of dry contact signal will be Active Closed, refer to the diagram below. When the signal is active, the signal pin on the DB9 connector will connect with the common Pin (Pin 5) via the relay.

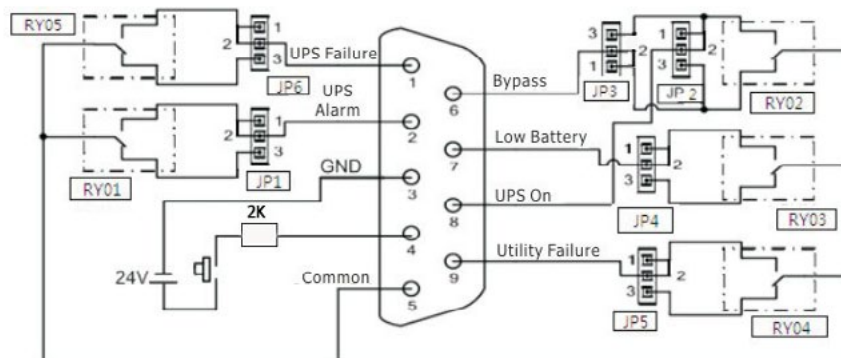

Connection for Active Closed

If Pin 3 connects with Pin 2 (Active Open) via the jumper, the status of dry contact signal will be Active Open, refer to the diagram below. When the signal is active, the signal pin on the DB9 connector will disconnect with the common Pin (Pin 5) via the relay.

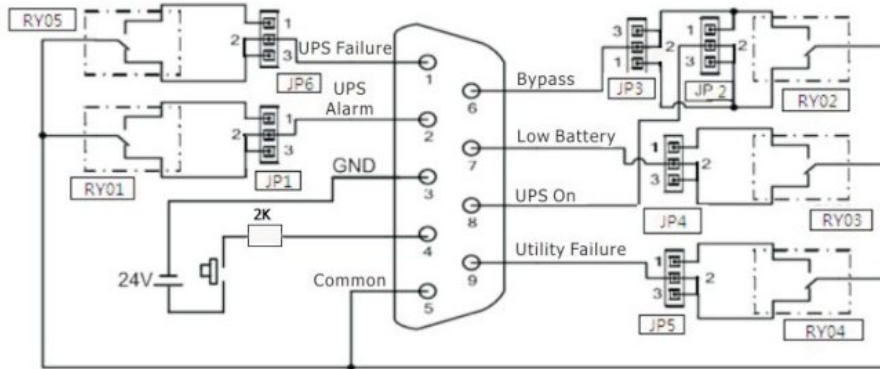

Connection for Active Open

Jumper Set-up

The jumpers can be easily found just behind the relays.



Pin 1 of jumper connection is located closest to the rear of the card. Pin 3 of the jumper connection is closest to the relays.

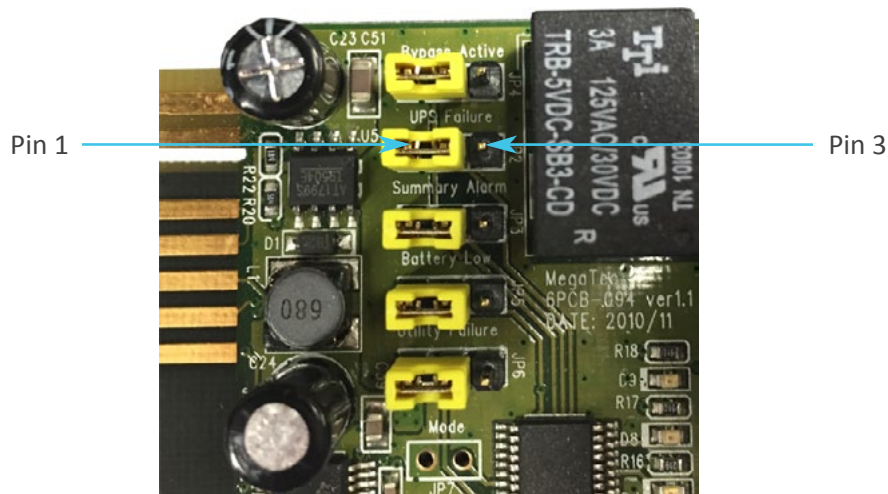

To achieve Active Closed dry-contact signal, the jumper should connect Pin 1 and Pin 2 as shown below.

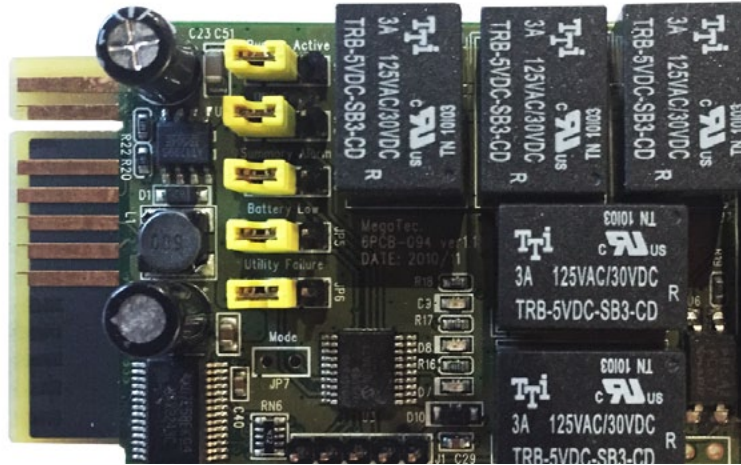

Jumper setting for Active Closed

To achieve Active Open dry-contact signal, the jumper should connect Pin 2 and Pin 3 as shown below.

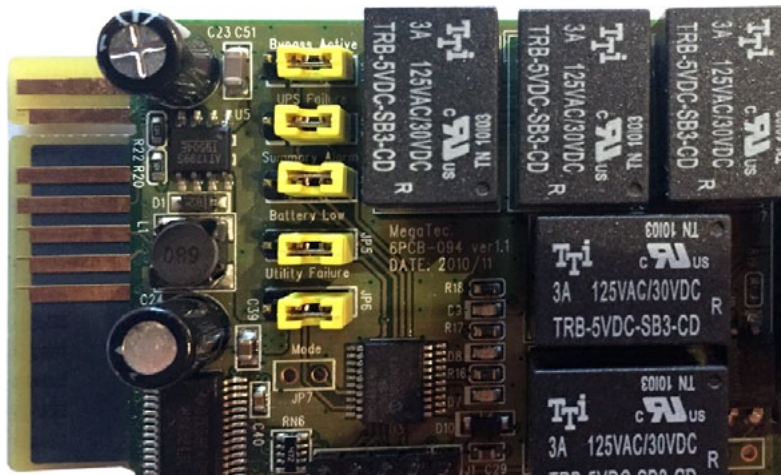

Jumper setting for Active Open

Jumper Functional Description

JP	Description	JP	Description
1	UPS Alarm (DB9, Pin 2)	4	Low battery (DB9, Pin 7)
2	UPS on (DB9, Pin 8)	5	Utility failure (DB9, Pin 9)
3	Bypass (DB9, Pin 6)	6	UPS failure (DB9, Pin 1)

Remote Shutdown Functional Description

To enable remote shutdown, apply ground to Pin 3 and 6V Pin 4 for a period of 3 to 5 seconds. UPS will shutdown 5 seconds later for a period of 5 seconds. UPS will auto restart after the 5 second shutdown, even if shutdown signal is still applied.