



R91 Online UPS

20kVA Model

User & Installation Manual

Table of Contents

Introduction.....	7
ProductDescription.....	7
Main Features.....	7
System Configuration.....	8
Unpacking the UPS.....	8
Installation Notes.....	9
External Protective Devices.....	9
Power Cables.....	10
Power Cables Connection.....	10
UPS Multi-Module Installation.....	12
CYCLON Battery Pack Connection.....	15
BP-XR4U480A Battery Pack Connection.....	16
Assembly.....	17
4 Post Rail Mounting.....	20
Multiple Battery Pack Connections.....	20
Installation and Setup.....	21
BP-XR2U480A Battery Pack Connection.....	22
Assembly.....	23
4 Post Rail Mounting.....	26
Multiple Battery Pack Connections.....	26
Installation and Setup.....	27
Operation.....	28
Operation Modes.....	28
Turn On / Off the UPS.....	29
Communication Port Definitions (RS232, RS485).....	35
LCD Display.....	36
Options.....	44
Troubleshooting.....	45

Specifications.....	46
Shipping List.....	46
Obtaining Service.....	47
Xtreme Power Conversion Limited Warranty.....	48

Thank you for selecting this uninterruptible power supply (UPS). It provides you with protection for connected equipment. **Please read this manual** before installing the R91-20KVA model as it provides important information that should be followed during installation and maintenance of the UPS and batteries, allowing you to correctly set up your system for the maximum safety and performance. Included is information on customer support and service, if it is required. If you experience a problem with the UPS, please refer to the Troubleshooting section in this manual to correct the problem. If the problem is not corrected, please collect information so that the Technical Support personnel can more effectively assist you.

Important Safety Instructions: (Save These Instructions)

CAUTION! (UPS having Internal Batteries): Risk of electrical shock – Hazardous live parts inside this unit are energized from the battery supply even when the input AC power is disconnected.

CAUTION! (No User serviceable Parts): Risk of electrical shock, do not remove cover. No user serviceable parts inside. Refer servicing to qualified service personnel.

CAUTION! (Non-isolated Battery supply): Risk of electric shock, battery circuit is not isolated from AC input, hazardous voltage may exist between battery terminals and ground. Test before touching.

WARNING! (Fuses): To reduce the risk of fire, replace only with the same type and size of fuse.

WARNING! Unit intended for installation in a controlled environment.

CAUTION! Do not dispose of batteries in a fire, the battery may explode.

CAUTION! Do not open or mutilate the battery, released electrolyte is harmful to the skin and eyes.

CAUTION! A battery can present a risk of electric shock and high short circuit current. The following precaution should be observed when working on batteries:

- Remove watches, rings or other metal objects.
- Use tools with insulated handles.

To reduce the risk of electric shock, disconnect the UPS from the main supply before installing a computer interface signal cable. Reconnect the power cord only after signaling interconnections have been made.

Servicing of batteries should be performed or supervised by personnel with knowledge of batteries and the required precautions. Keep unauthorized personnel away from batteries.

These UPS units are extremely heavy. Caution should be taken in moving and positioning equipment. The instructions contained within this safety manual are deemed important and should be closely followed at all times during installation and follow-up maintenance of the UPS and batteries.

**CAUTION**

The unit has a dangerous amount of voltage. If the UPS indicator is on, the unit's outlets may have a dangerous amount of voltage even when not plugged into the wall outlet because the battery may continue to supply power.

Care should be taken to undertake installation indoors, free from electrically-conductive particles which are under temperature and humidity control, in order to reduce the risk of electric shock.

It is best to disconnect the device using the power supply cord. Ensure that the equipment is placed in a position near the outlet where easily accessible.

Except for replacing the batteries, all servicing on this equipment must be carried out by qualified service personnel.

Before conducting any maintenance, repair, or shipment, first ensure that everything is turned off completely and disconnected.

For additional safety instructions, please use the Safety Manual as a reference.

Special Symbols

The following symbols used on the UPS warn you of precautions:



RISK OF ELECTRIC SHOCK - Please observe the warning that a risk of electric shock is present



CAUTION: REFER TO OPERATOR'S MANUAL - Refer to the operator's manual for additional information, such as important operating and maintenance instructions.



SAFE GROUNDING TERMINAL - Indicates primary safe ground



Please do not discard of the UPS or the UPS batteries as the UPS may have valve-regulated lead-acid batteries. Please recycle batteries appropriately.

Introduction

The information provided in this manual covers three-phase 20kVA uninterruptible power systems, its basic functions, operating procedures, options available and emergency situations. It also includes information on how to ship, store, handle, and install the equipment. Only detailed requirements of the UPS units are described herein, and installation must be carried out in accordance with this manual. Electrical installation must also carefully follow local legislation and regulations. Only qualified personnel should conduct these installations as failure to acknowledge electrical hazards could prove to be fatal.

Product Description

Many different kinds of sensitive electrical equipment can be protected by an Uninterruptible Power Supply (UPS) including computers, workstations, process control systems, telecommunications systems, sales terminals, other critical instrumentation, etc. The purpose of the UPS is to protect these systems from poor quality utility power, complete loss of power, or other associated problems.

Electrical interference exists in many forms, causing problems in AC power, from lightning, power company accidents and radio transmission motors, air conditioners, and vending machines. Protection of sensitive electrical equipment is vital to protect against power outages, low or high voltage conditions, slow voltage fluctuations, frequency variations, differential and common-mode noise, transients, etc.

To prevent power line problems from reaching critical systems causing damage to software, hardware, and equipment malfunctions, the UPS maintains constant voltage, isolating critical load output and cleaning the utility AC power.

Main Features

This is a three phase input / three phase output high-frequency online UPS. The UPS protects against power failures, power sag, power surge, under-voltage, over-voltage, line noise, frequency variations, switching transients, and harmonic distortion which can all cause critical problems to supported sensitive electronic equipment in the market today.

Functions and Features

- 3 phase input/output high-density UPS
- Digital Control
 - The UPS is controlled by Digital Signal Processor (DSP) which increases reliability, performance, self-protection, self-diagnostics, etc.
- Modular Design
- Battery Configuration
 - The battery voltage can be configured based on needs
- Charging Configuration
 - The charging current can be customized to meet site requirements
- Intelligent Charging Method
 - 1st stage = high current constant current charging to restore batteries to 90% capacity
 - 2nd stage = constant current charging to assure batteries remain fully charged
 - 3rd stage = float charge

The 3-stage charging method extends the life of the batteries and guarantees rapid recharging
- LCD Display
 - Both LED and LCD displays allow for ease of use and availability of critical UPS status and operational parameters, including: input/output voltage, frequency and load %, battery %, ambient tem-

- perature, etc.
- EPO Function

System Configuration

The UPS device and the external batteries make up the system. Depending on the site and load requirements of the installation, certain additional options are available for the solution.

Planning a UPS system, the following should be taken into consideration:

- The total demand of the protected system shall dictate the output power rating (VA). Allow a margin for future expansion or calculation inaccuracies from measured power requirements.
- Backup time required will indicate the battery size needed. If the load is less than the UPS nominal power rating, then actual backup time is longer.
- The following options are available:
 - o Connectivity Options –SNMP/WEB card
 - o Extended Battery Packs - minimum 1 required

See the Specification section of this manual for additional model information.

Unpacking the UPS

1. Do not lean the UPS against anything when moving it out of the packaging.
2. Check the physical appearance of the UPS to see if it was damaged during transportation. Do not switch on the UPS if damage is found. Please contact your dealer or distributor immediately for assistance.
3. Check the accessories according to the packing list to assure that you have all required pieces.



R91-20K front view

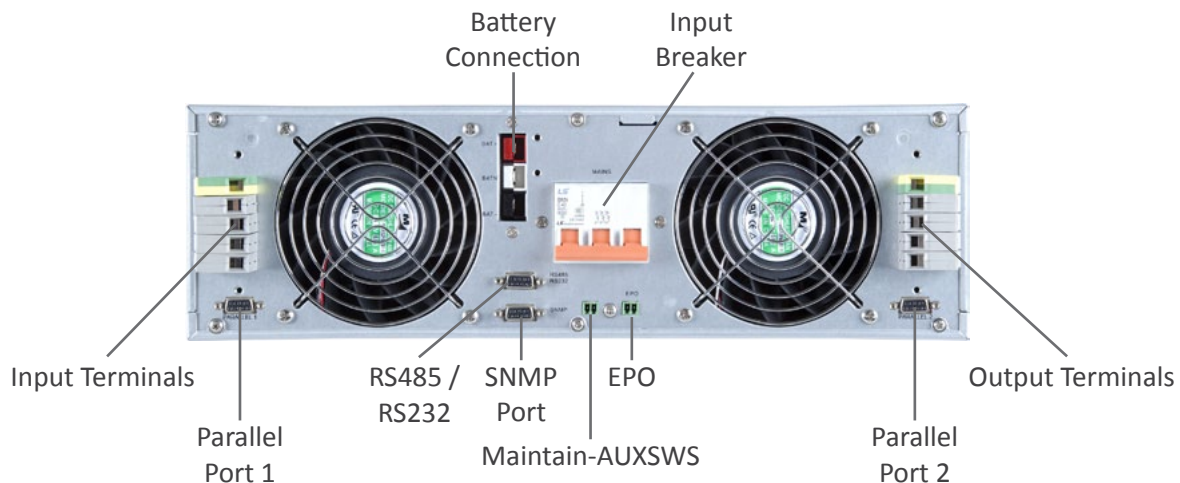

R91-20KVA rear view diagram

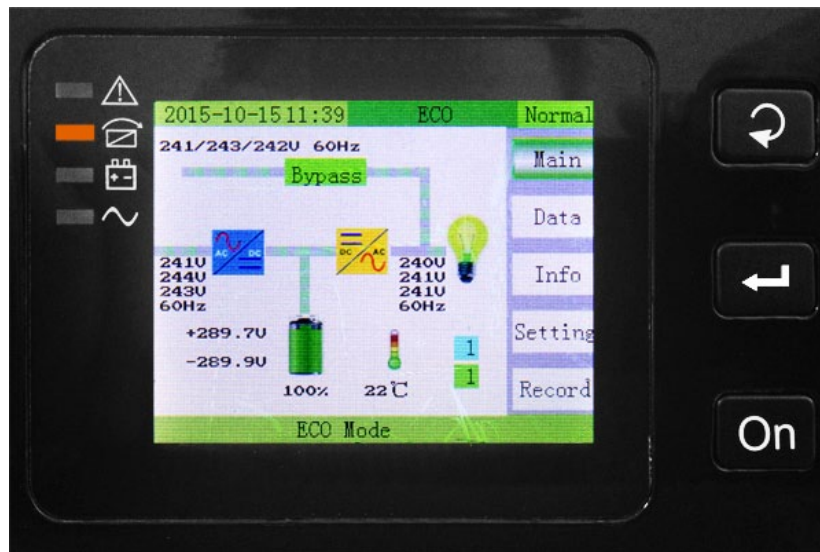

Front panel

Installation Notes

- Place the UPS in a clean, stable environment, avoiding vibration, dust, humidity, flammable gas and liquid, corrosive objects, etc. Check the operating temperature of the room where the UPS is being installed to assure it is within range of UPS specification.
- Batteries should be installed in an environment where the temperature is within the required specifications of the product. Temperature is a major factor in determining battery life and capacity. Normal battery installation requires the temperature be maintained from 15°C to 25°C. Keep batteries away from heat sources and main air ventilation areas.



WARNING!

Typical battery performance data is quoted for an operating temperature between 20°C and 25°C. Operating above this range will reduce the battery life while operation below this range will reduce the battery capacity. If the equipment is not to be installed immediately, it must be stored in a room so as to protect it against excessive heat and humidity sources.



CAUTION!

An unused battery must be recharged every 6 months. Temporarily connecting the UPS to a suitable AC source and activating the UPS for the time required to recharge the batteries is required.

- To monitor the UPS with the software, simply connect the RS232 cable to the UPS and to a computer.

External Protective Devices

For safety reasons, it is necessary to install an external circuit breaker at the input AC utility and to the battery.

External Battery

The UPS and its associated batteries are protected against the effect of over-current through a DC compatible thermo-magnetic circuit breaker located close to the battery.

UPS Output

Any external distribution board used for load distribution shall be fitted with protective devices so as to avoid the risk of UPS overload.

Over-Current Protection

A protection device shall be installed at the distribution panel of the incoming utility power, and should identify the power cables current capacity as well as the overload capacity of the system.

**CAUTION!**

Select a thermo-magnetic circuit-breaker with an IEC 60947-2 trip curve D (normal) for 125% of the current as listed below. **40A Input Circuit Breaker required.**

Power Cables

The cable design shall comply with the voltages and currents provided in this section, and in accordance with local electrical codes.

**WARNING!**

UPON STARTING, PLEASE ENSURE THAT YOU ARE AWARE OF THE LOCATION AND OPERATION OF THE EXTERNAL ISOLATORS WHICH ARE CONNECTED TO THE UPS INPUT/BYPASS SUPPLY OF THE UTILITY DISTRIBUTION PANEL. CHECK TO SEE IF THESE SUPPLIES ARE ELECTRICALLY ISOLATED, AND POST ANY NECESSARY WARNING SIGNS TO PREVENT ANY INADVERTENT OPERATION

Cable Sizes

UPS MODEL	CABLE SIZES (THHW wiring at 75°C)			
	AC INPUT	AC OUTPUT	DC INPUT	GROUNDING
R91-20K	8 awg	8 awg	6 awg	8 awg

**CAUTION!**

Protective earth ground cable: connect each cabinet to an earth ground, following the shortest route possible.

**WARNING!**

FAILURE TO FOLLOW ADEQUATE GROUNDING PROCEDURES MAY RESULT IN ELECTROMAGNETIC INTERFERENCE OR IN HAZARDS INVOLVING ELECTRICAL SHOCK AND FIRE.

Power Cables Connection

After the equipment has been properly positioned and secured, connect the power cables as described below.

Verify the UPS is totally isolated from its external power source and all circuit breakers to the UPS are open. Check to see that everything is electrically isolated, and post any necessary warning signs to prevent inadvertent operation of the breakers.

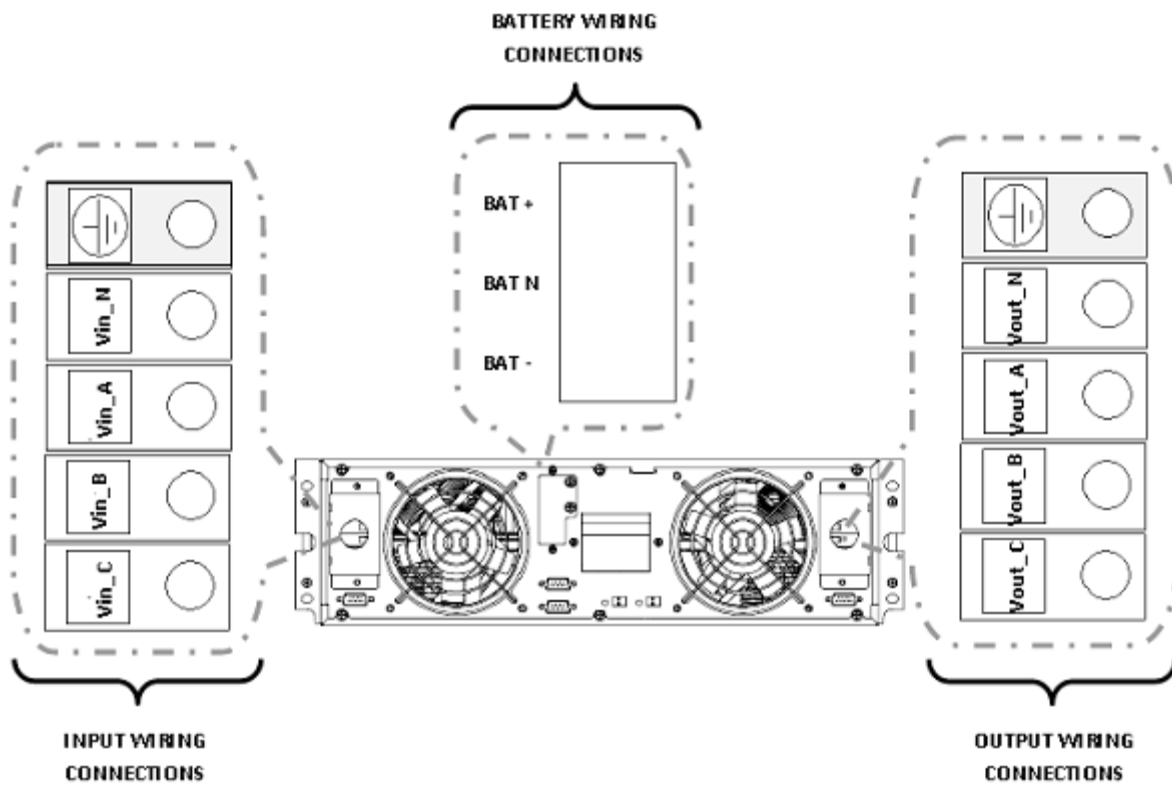

Power cable connection diagram

Select the appropriate power cable size, paying attention to the diameter of the connection terminal of the cable, which should be greater than or equal to the connection posts.

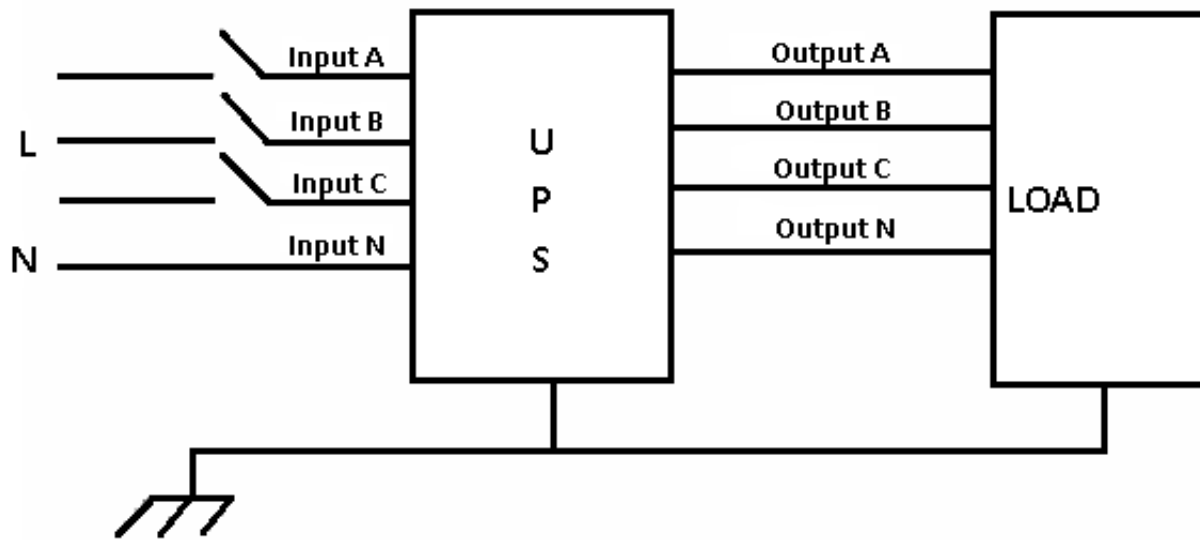

Wiring diagram

**WARNING!**

IF THE LOAD EQUIPMENT IS NOT READY TO ACCEPT POWER WHEN THE UPS INSTALLATION IS OCCURRING, ENSURE THAT THE UPS OUTPUT CABLES ARE SAFELY ISOLATED AT THE CABLE ENDS.

**CAUTION!**

The earth ground and neutral bonding arrangement must be in accordance with local and/or national electrical code practices.

UPS Multi-Module Installation

The basic installation procedure for a parallel system consisting of two or more R91-20KVA modules is that same as that of a single module. The following provides installation procedures related to a parallel system.

Cabinet Installation

Connect all R91-20KVA UPS required in the parallel system as shown in the diagram below.

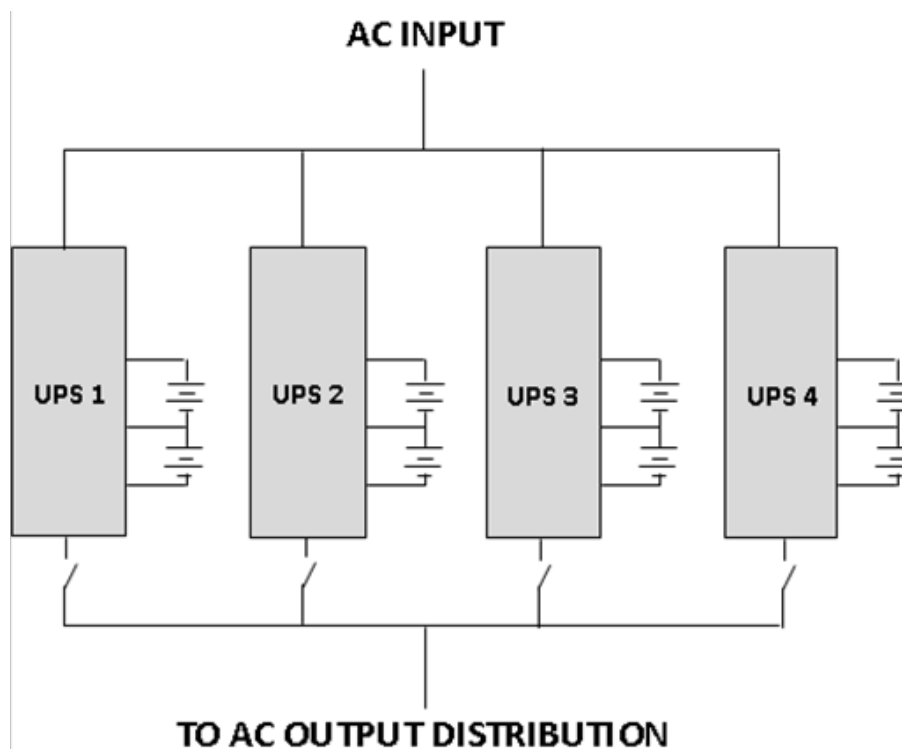
**WARNING!**

MAKE SURE THE N, A(L1), B(L2), AND C(L3) WIRING IS CORRECT, AND THAT GROUND IS CONNECTED.

Parallel Cable Installation

The shielded and double insulated control cables must be interconnected in a ring-configuration between UPS modules as shown in the diagram below. The parallel control board is mounted in each UPS module. The ring-configuration ensures high-reliability of the control function.

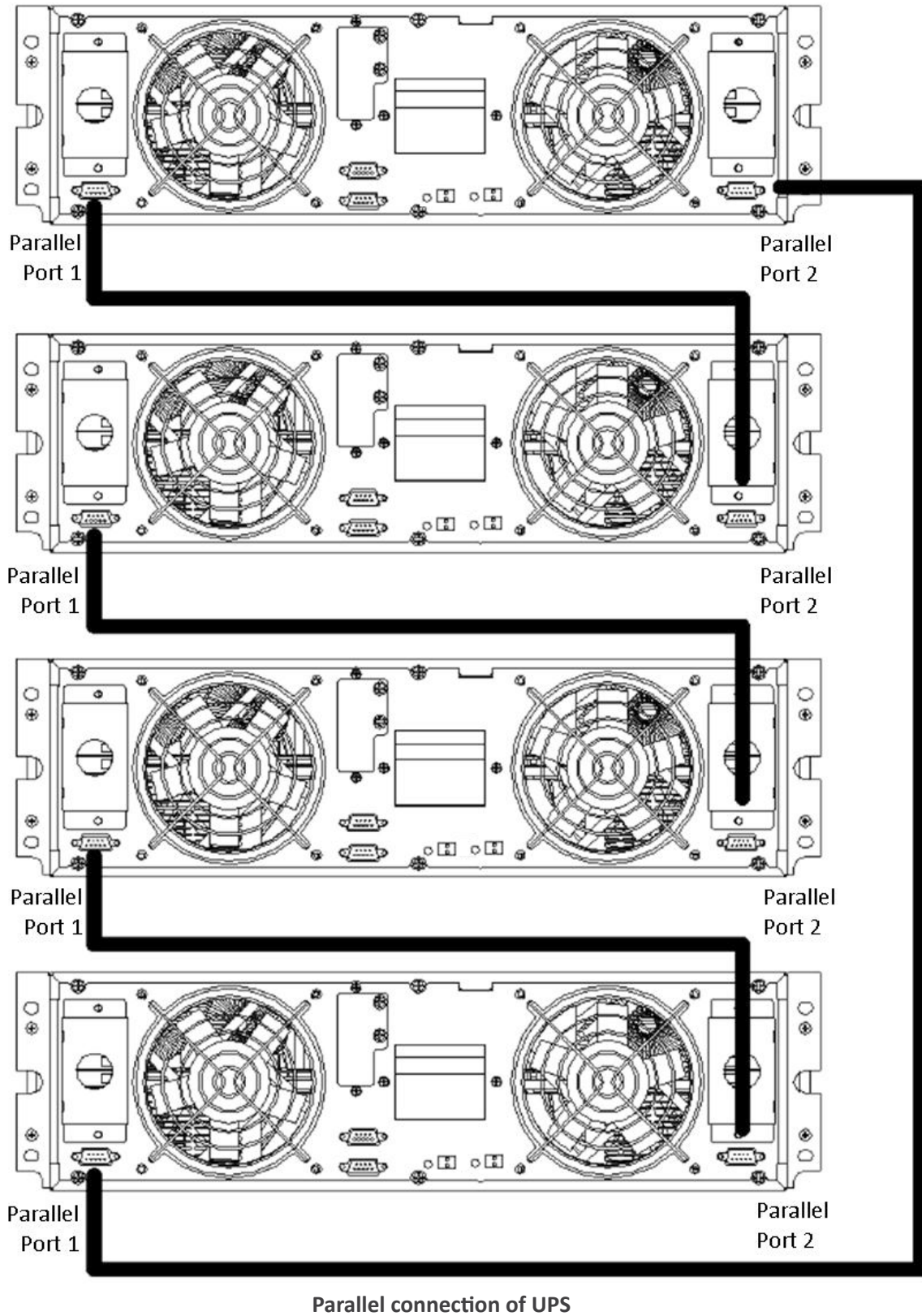

Remote Emergency Power Off (EPO) for Parallel Systems

EPO for parallel systems must be connected in parallel and installed as shown below. Once the EPO function of one of the UPS in the parallel system is activated, the UPS will send out a remote command and shut down the other UPS's in the parallel system.



CAUTION!

The remote emergency kill switch must be voltage-free and "normally open".

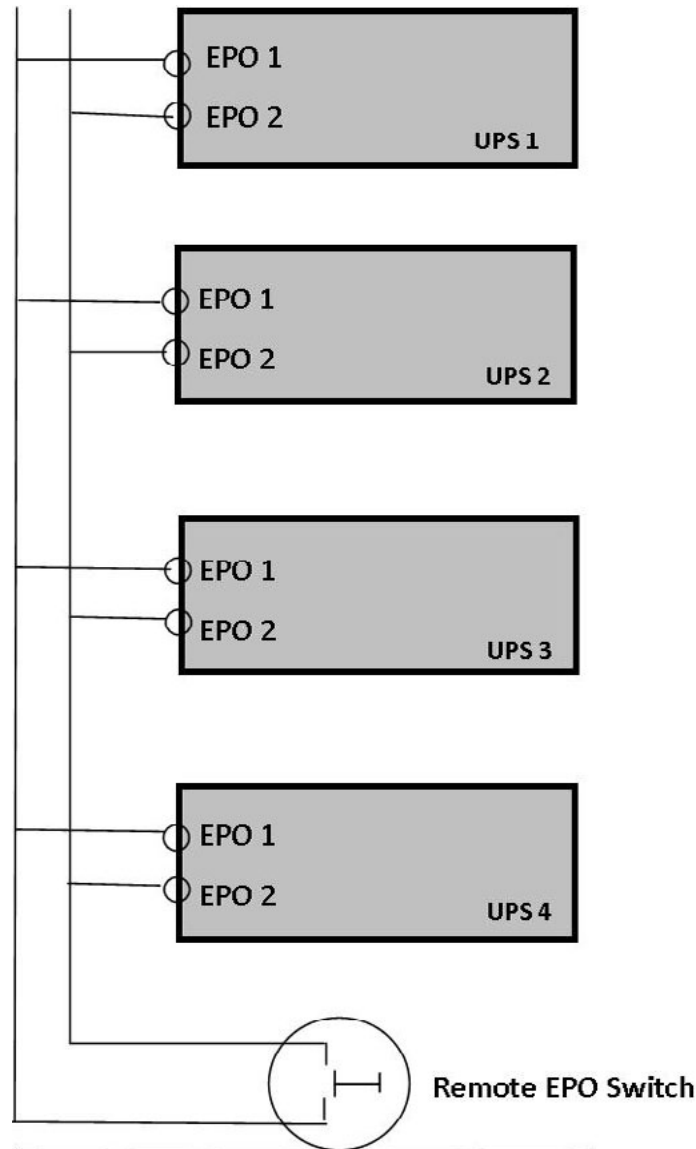

EPO connections for parallel systems

Requirements for a Parallel System

A group of parallel UPS modules behave as one large UPS system with the advantage of presenting higher reliability. In order to assure that all modules are equally utilized and comply with relevant wiring regulations, please follow the requirements below.

1. All UPS modules must be of the same rating and be connected to the same bypass source.
2. The Bypass and Utility input sources must be referenced to the same neutral potential.
3. The outputs of all the UPS modules must be connected to a common output bus.

4. The length and specification of power cables including the bypass input cables and the UPS output cabinets should be the same size. This facilitates load sharing when operating in bypass mode.
5. Up to 4 UPS modules may be paralleled with common battery if desired.

CYCLON Battery Pack Connection

The CYCLON battery pack contains four identical battery trays. Each tray contains 60 5AH CYCLON cells connected in series. The four trays are then connected in series. The following three diagrams respectively display battery pack internal connections, internal cell connections in each individual tray and battery pack external connections to UPS and another battery pack.

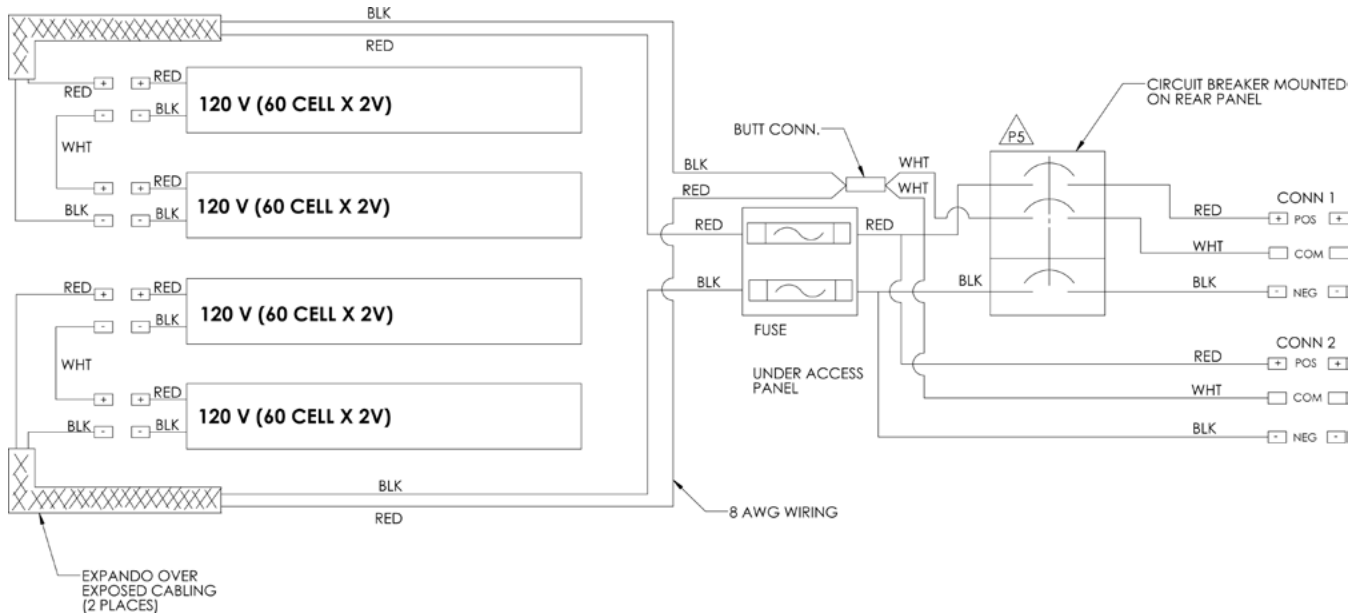

R91-BPSYS battery pack wiring diagram



R91-BPSYS battery module connection



CAUTION!

Ensure correct polarity of the battery string series connection. DO NOT mix batteries with different capacity or different brands, or new or old batteries.



WARNING!

ENSURE CORRECT POLARITY OF STRING END CONNECTIONS TO THE BATTERY CIRCUIT BREAKER, AND FROM THE BATTERY CIRCUIT BREAKER TO THE UPS TERMINALS (I.E. (+) TO (+) / (-) TO (-) / (N) TO (N)). DISCONNECT ONE OR MORE BATTERY CELL LINKS IN EACH TIER. DO NOT RECONNECT THESE LINKS AND DO NOT CLOSE THE BATTERY CIRCUIT BREAKER UNLESS ALL CONNECTIONS ARE PROPERLY CHECKED AND APPROVED.

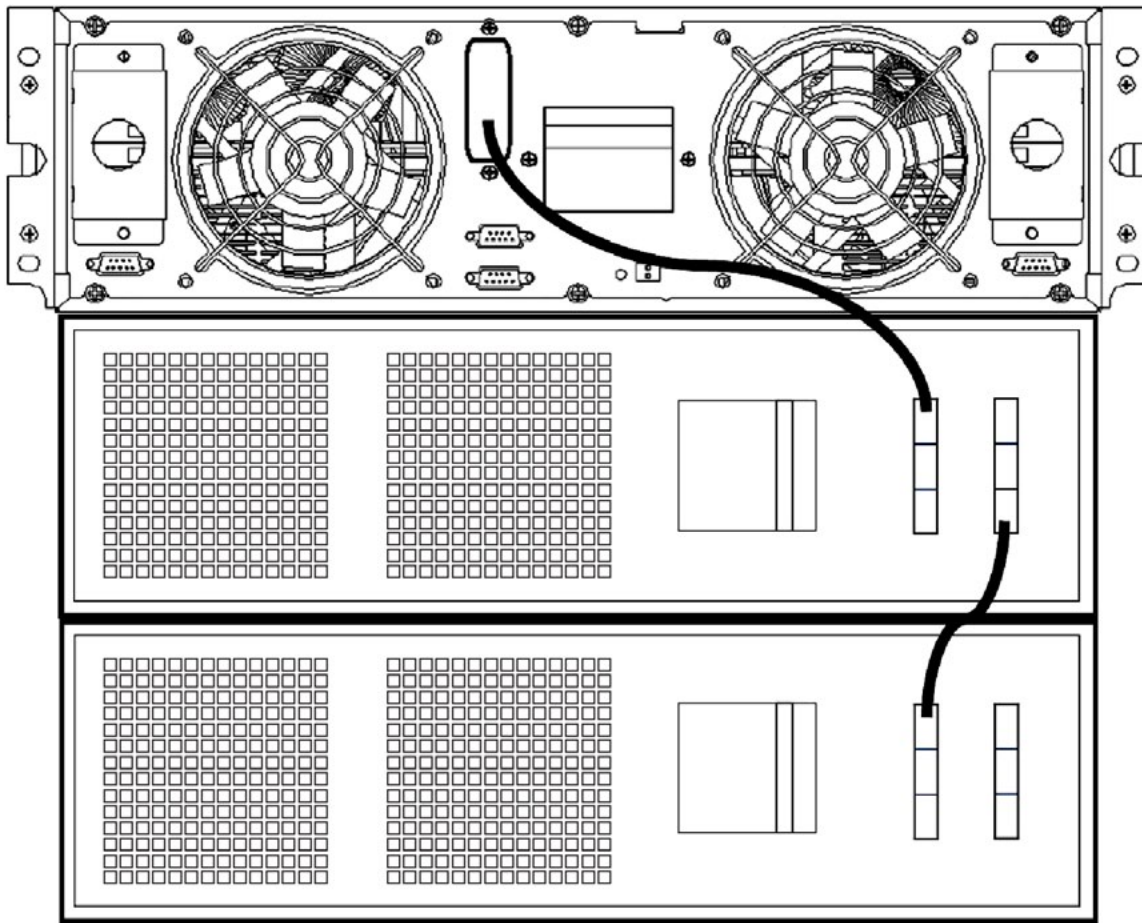

R91-20K to R91-BPSYS battery connection

BP-XR4U480A Battery Pack Connection

The BP-XR4U480A battery pack dimension is 443W x 861.5D x 175H mm (17.4 x 33.9 x 7.0 in) and unit weight is 127 kgs (280 lbs). It includes battery connection cables, breaker, fuse, terminal, etc, with a maximum capacity of 40 pcs CSB UPS12580 batteries inside. The battery connection could be configured to output $\pm 240V$, two groups batteries connect in series as BAT+, N, BAT-.

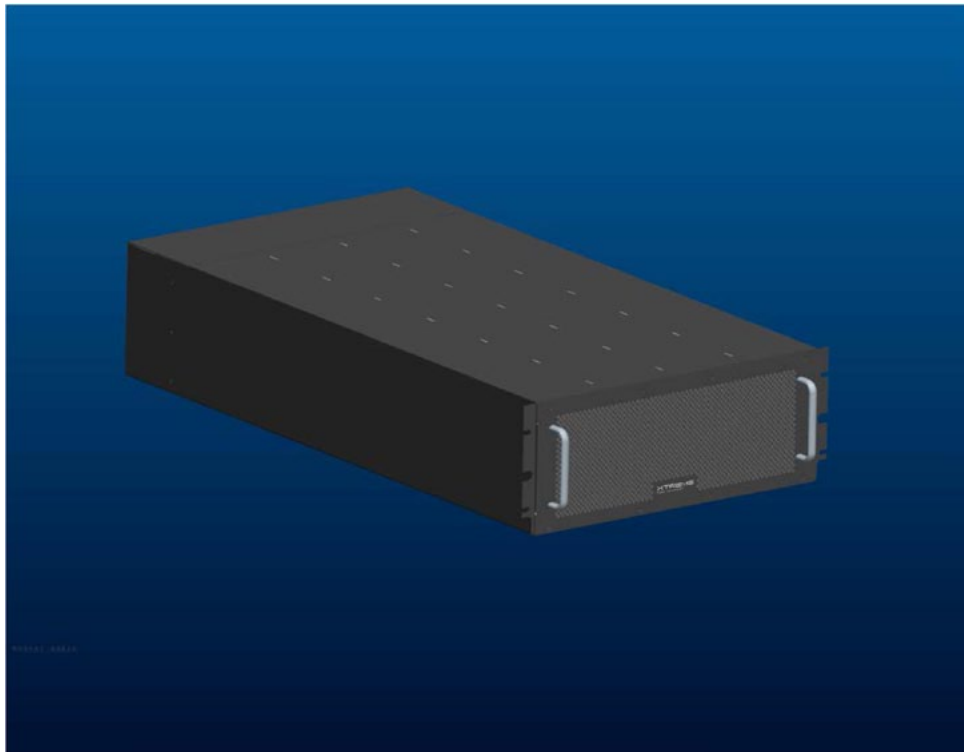

Complete BP-XR4U480A cabinet

Assembly

Dismount the Cabinet Shell

Put the battery pack on a level, pull of bolts at the right side battery tray, than pull out the battery tray, remove the battery tray top covers for easier battery installation and connection, as shown below

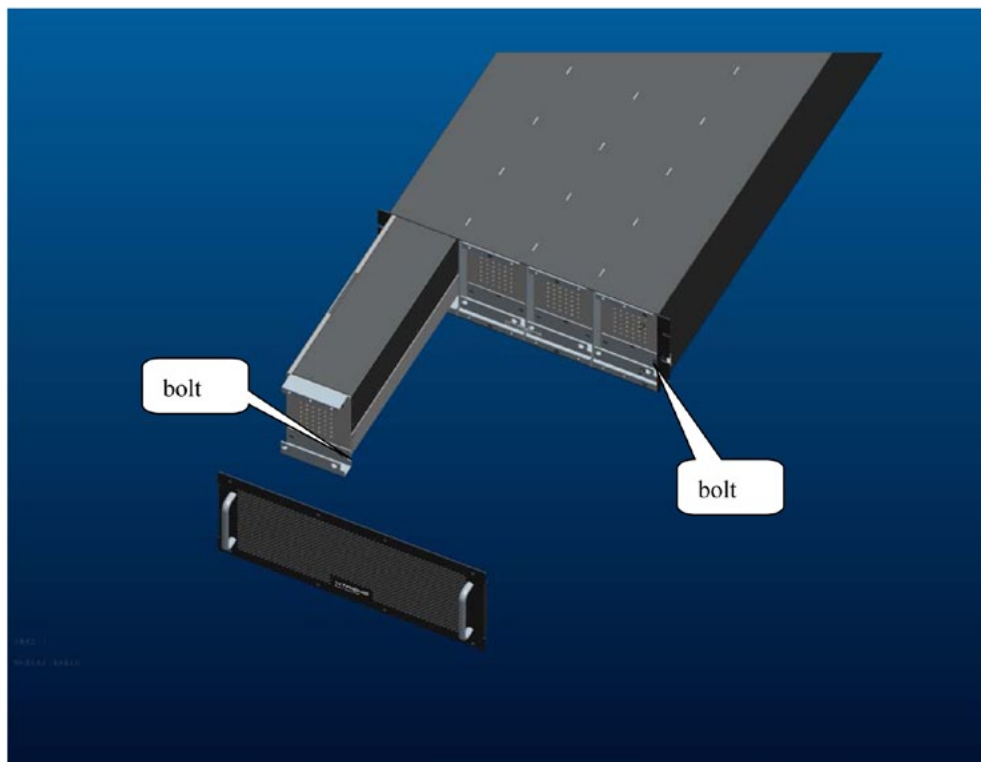

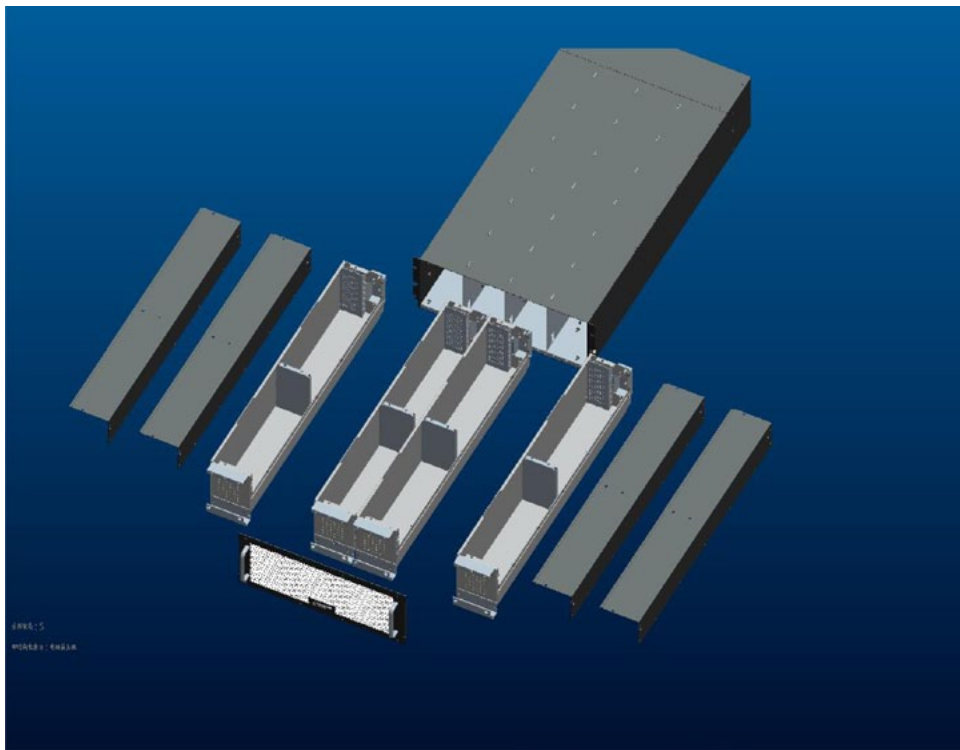

Battery Installation and Connection

Users need 40 pcs batteries, divide into 2 groups. Each group has 20 pcs batteries in series, as (BAT+ N BAT-) shown below.

40 pcs batteries installation and connection:

Each battery tray fit 10pcs batteries, then connect the batteries as shown in below pictures.

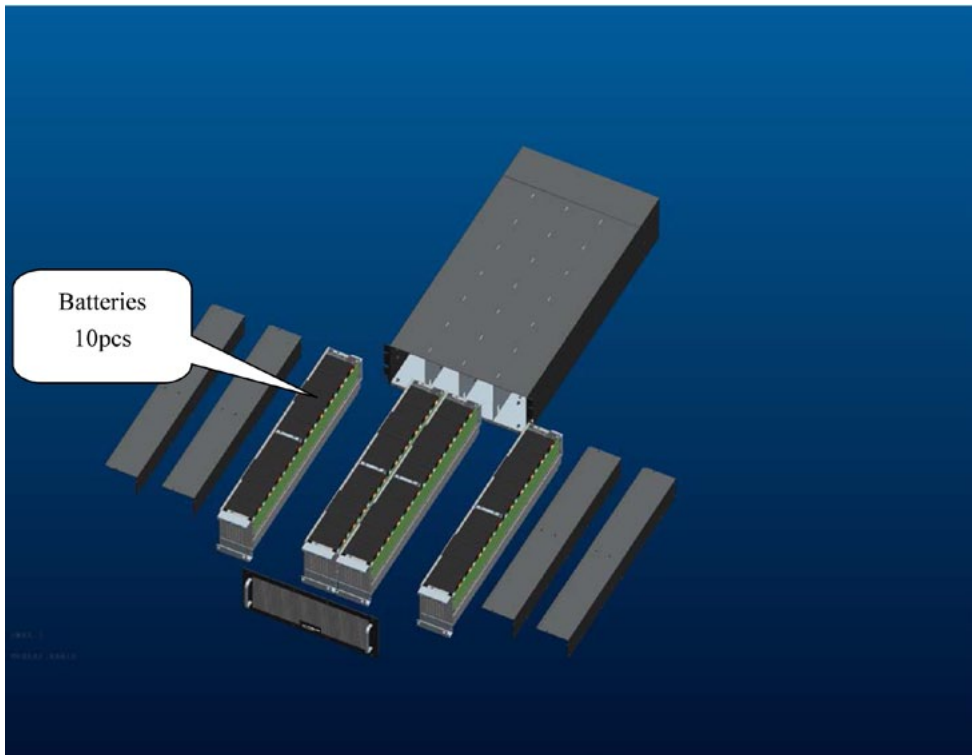

40pcs batteries installation

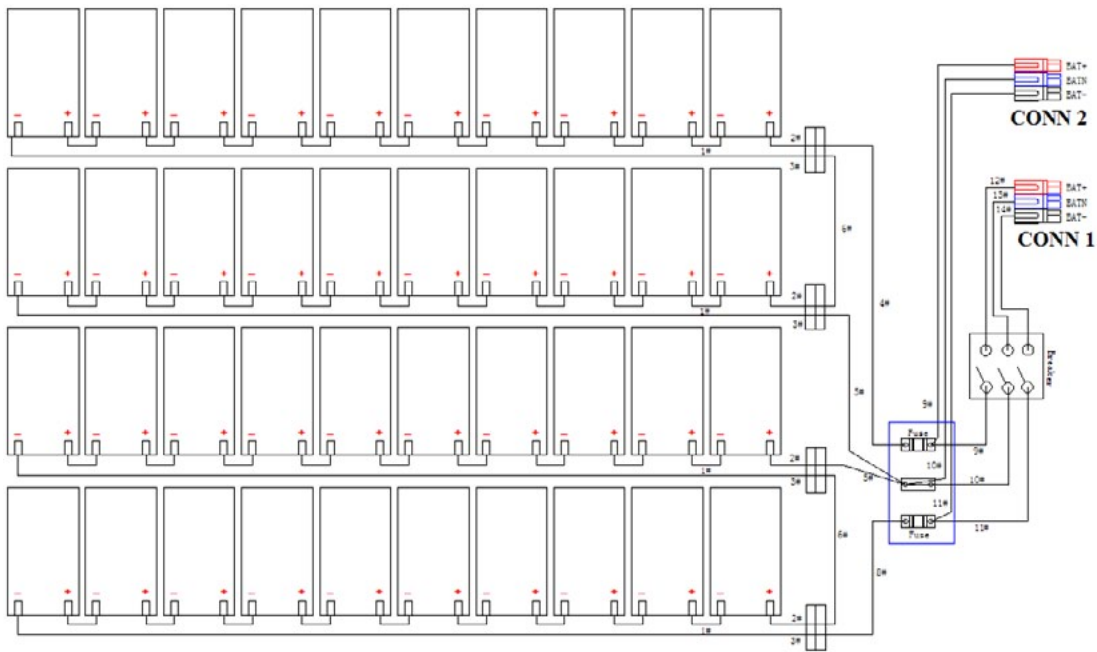

40 pcs batteries connection

After the battery installation and connection done, check if BAT+ to N & N to BAT- voltages are correct with multi-meter or other equipment. Install the cover if the voltages are correct.

Note: Battery “+” “-” poles cannot be reversed, also cannot short the battery “+” “-” poles, otherwise batteries would be damaged or other accidents would happen. Don’t touch the battery “+” “-” poles at the same time. It’s better only single man make the operation.

Fuse in Battery Pack

The battery pack has 2 x fuses inside as shown in below picture.

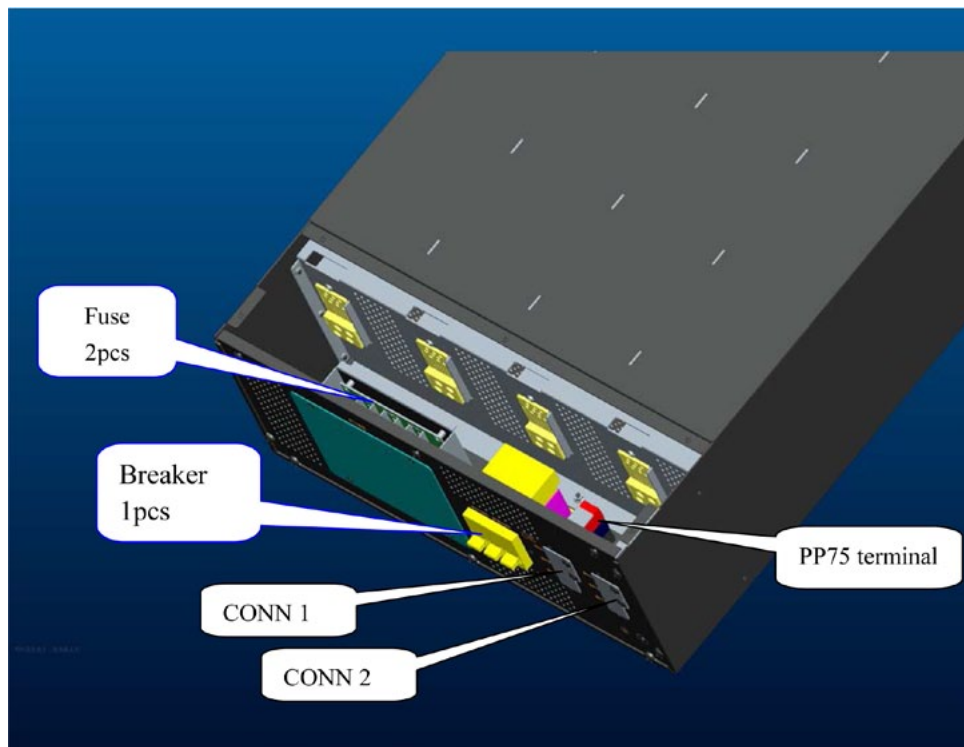

4 Post Rail Mounting

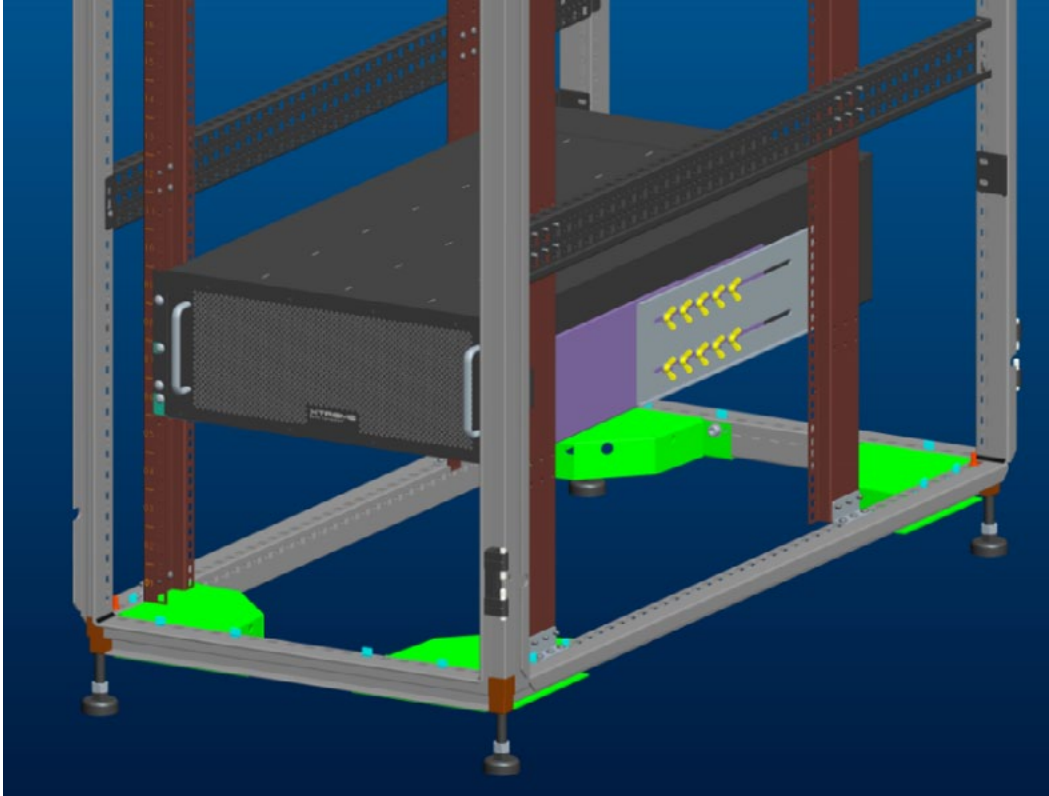

Multiple Battery Pack Connections



CAUTION!

Ensure correct polarity of the battery string series connection. DO NOT mix batteries with different capacity or different brands, or new or old batteries.



WARNING!

ENSURE CORRECT POLARITY OF STRING END CONNECTIONS TO THE BATTERY CIRCUIT BREAKER, AND FROM THE BATTERY CIRCUIT BREAKER TO THE UPS TERMINALS (I.E. (+) TO (+) / (-) TO (-) / (N) TO (N)). DISCONNECT ONE OR MORE BATTERY CELL LINKS IN EACH TIER. DO NOT RECONNECT THESE LINKS AND DO NOT CLOSE THE BATTERY CIRCUIT BREAKER UNLESS ALL CONNECTIONS ARE PROPERLY CHECKED AND APPROVED.

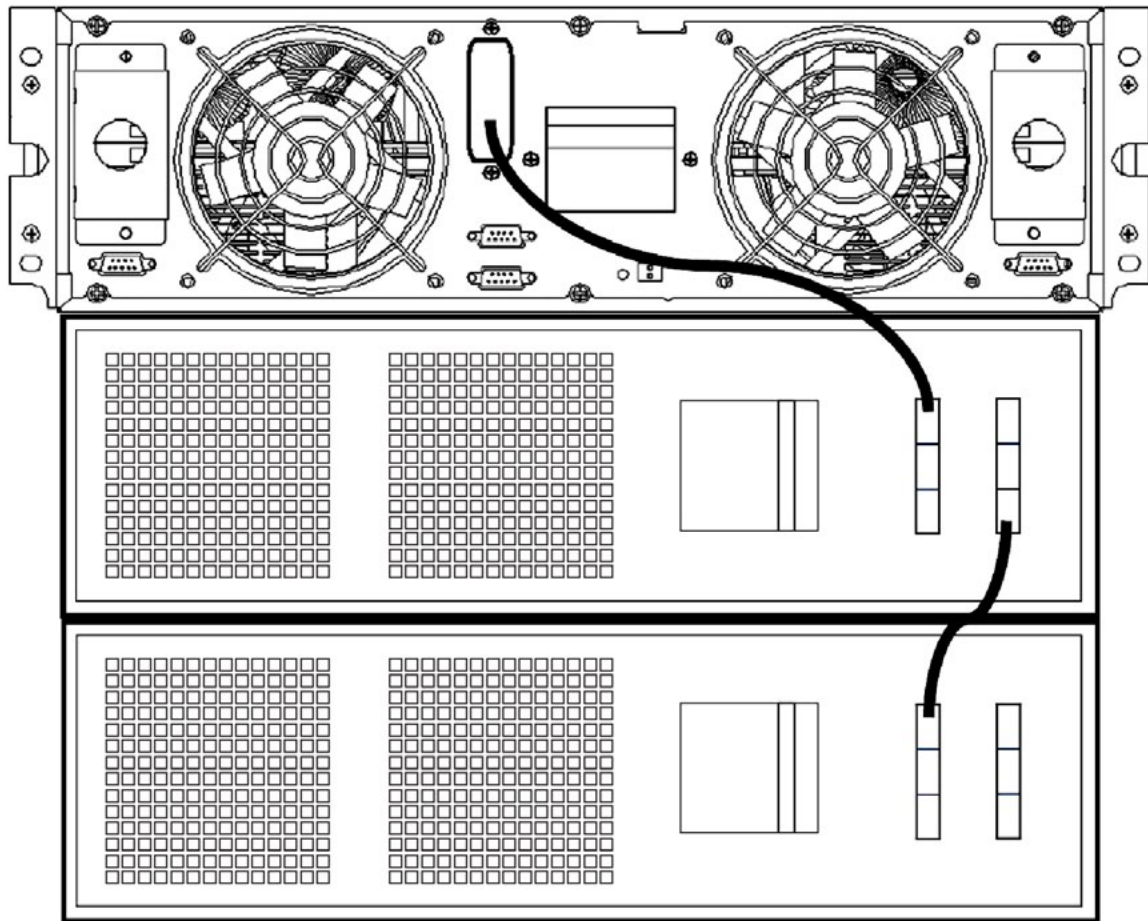

R91-20K to BP-XR4U480A battery connection

Installation and Setup

Note: Before installation, please inspect the unit. Be sure that nothing inside the package is damaged. Please keep the original packing material in a safe place for future use.

Unpacking & Inspection

Attention: Any damage to packing should be noted at the time of receipt with the delivery carrier

Remove the shelf kit, battery enclosure, and battery modules from the packaging.

Note: The battery modules are very heavy, be cautious when unpacking and lifting the unit to avoid injury.

Selecting Installation Position

It is necessary to select a proper environment to install the unit, in order to minimize the possibility of damage to the battery system and extend the life of the batteries. Please follow the instructions below:

1. Do not block the air-flow to the ventilation openings of the unit.
2. Please ensure the installation site environmental conditions are in accordance with the unit's working specifications to avoid overheat and excessive moisture.
3. Do not place the unit in a dusty or corrosive environment or near any flammable objects.
4. This unit is not designed for outdoor use.

Enclosure Installation

Note: Shelf kit must be installed per battery enclosure.

1. Add moveable cage nuts to desired front and rear location for shelf kit and battery enclosure.
2. Attach shelf kit into the rack with screws at front and rear.
3. Slide the battery enclosure from the front into the rack onto the shelf kit.
4. Fasten front and rear mounting ears to battery enclosure
5. Attach the mounting ears of the battery enclosure into the shelf kit and rack with screws at front and rear.

Battery Module Installation

1. Remove front cover from the battery enclosure.
2. Slide in battery modules.
3. Secure front cover in place.
4. Remove UPS connection cover from battery pack and connect the Anderson connector to UPS.

BP-XR2U480A Battery Pack Connection

The BP-XR2U480A battery pack dimension is 442W x 1086D x 86H mm (17.4 x 42.8 x 3.4 in) and unit weight is 88.5 kgs (195 lbs). It includes battery connection cables, breaker, fuse, terminal, etc, with a maximum capacity of 40 pcs 12V/5AH batteries inside. The battery connection could be configured to output $\pm 240V$, two groups batteries connect in series as BAT+, N, BAT-.

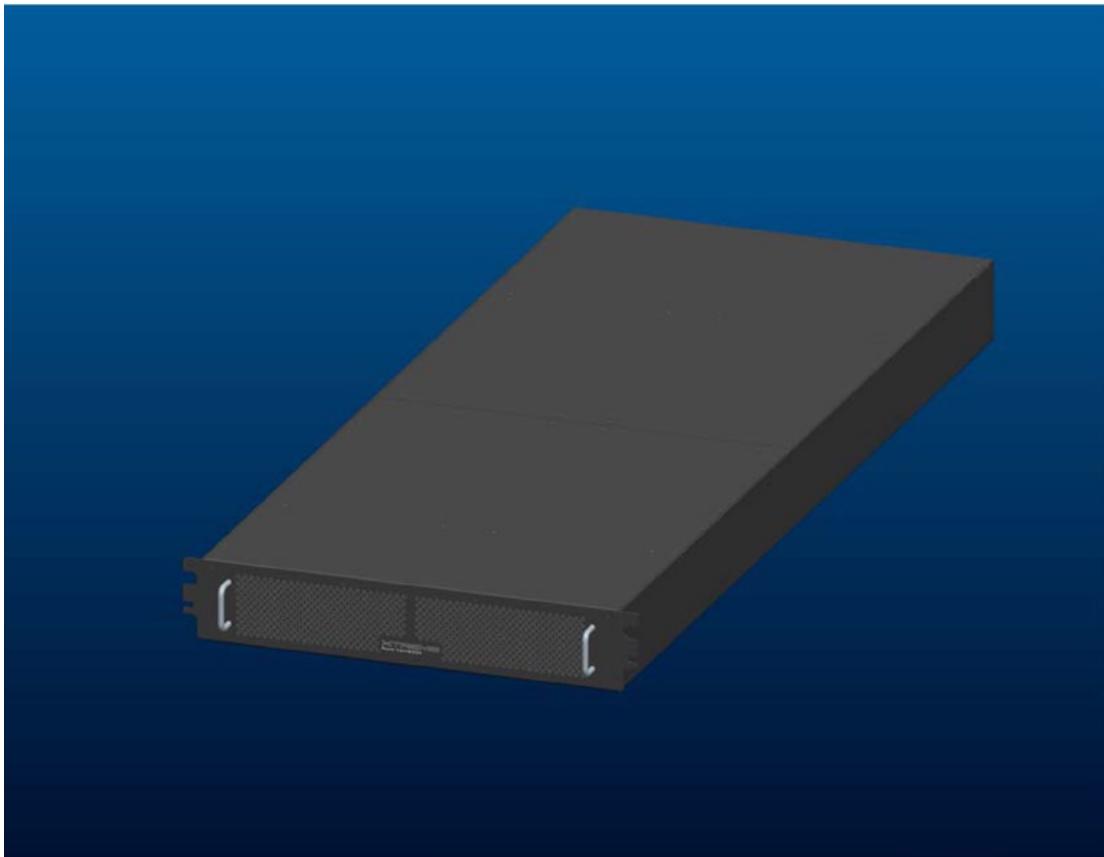

Complete BP-XR2U480A cabinet

Assembly

Dismount the Cabinet Shell

Put the battery pack on a level, remove the battery pack top covers, pull out the battery tray and remove the battery tray layering for easier battery installation and connection, as shown below.

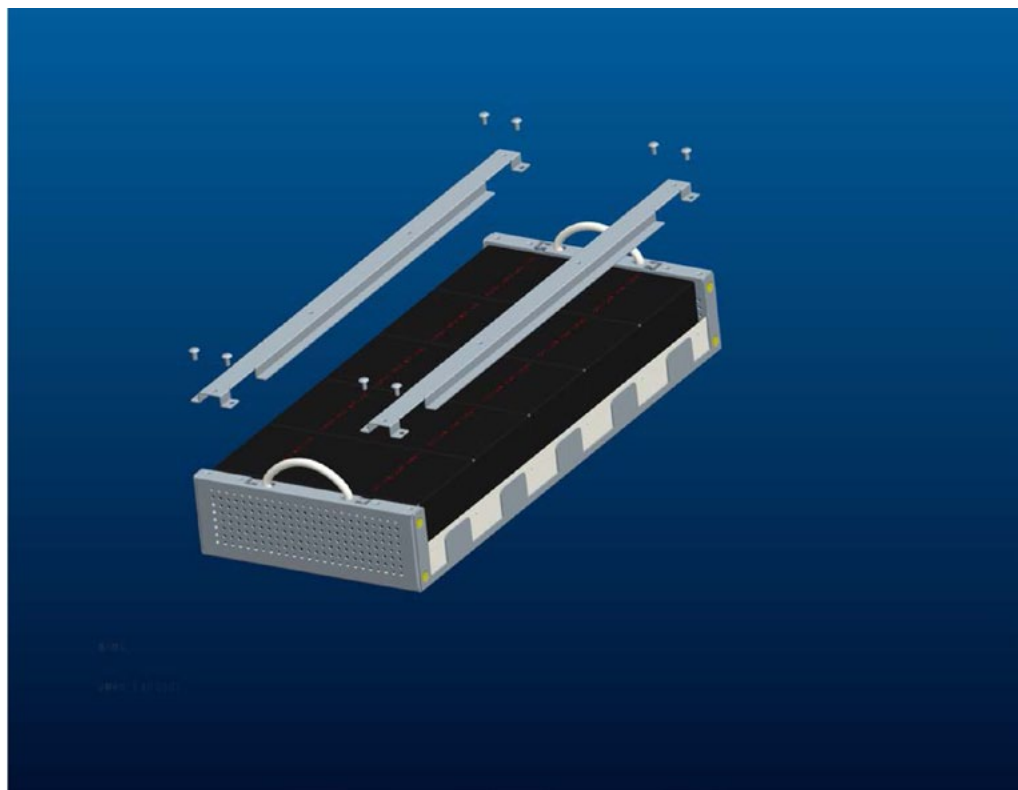
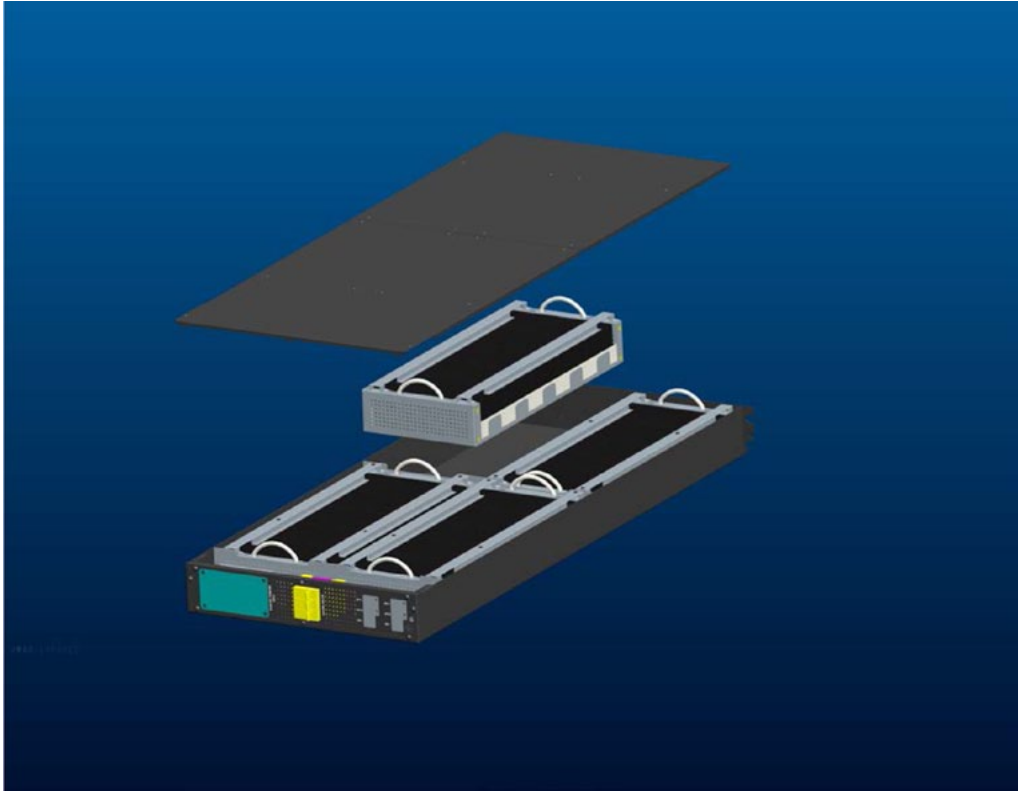

Battery Installation and Connection

Users need 40 pcs batteries, divide into 2 groups. Each group has 20 pcs batteries in series, as (BAT+ N BAT-) shown below.

40 pcs batteries installation and connection:

Each battery tray fit 10pcs batteries, then connect the batteries as shown in below pictures.

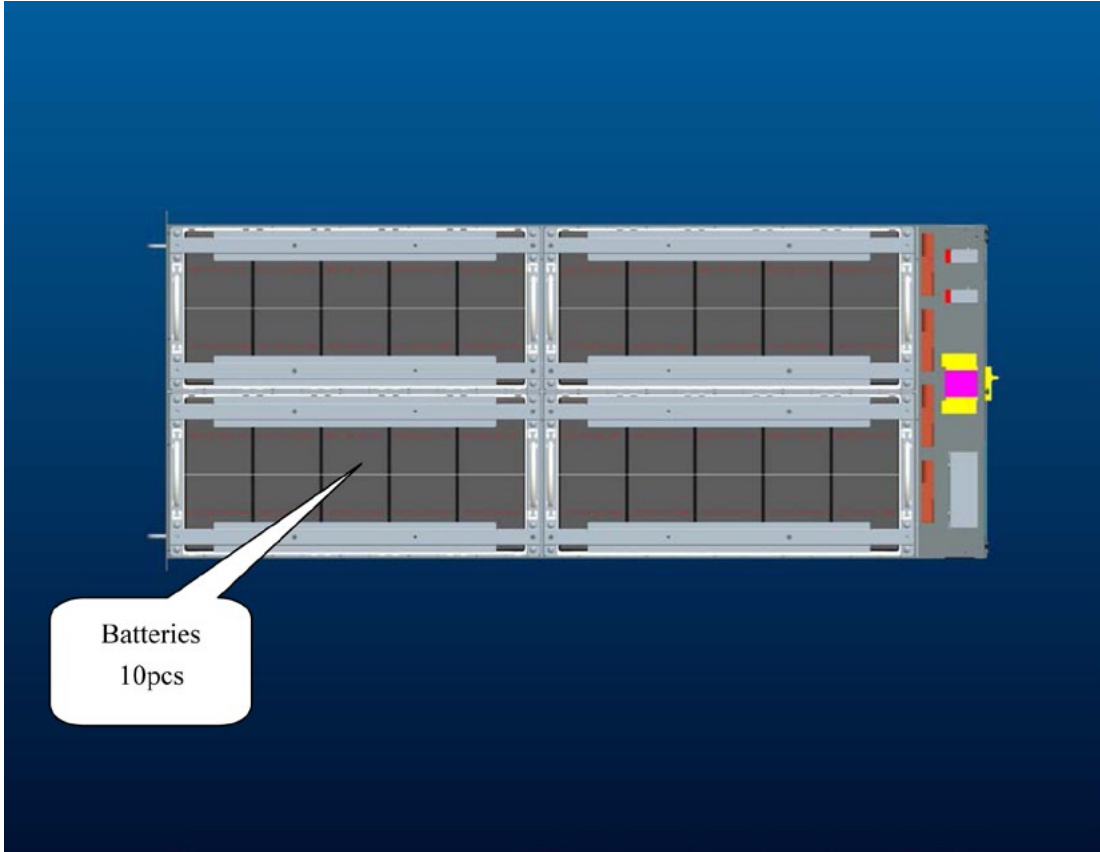

40pcs batteries installation

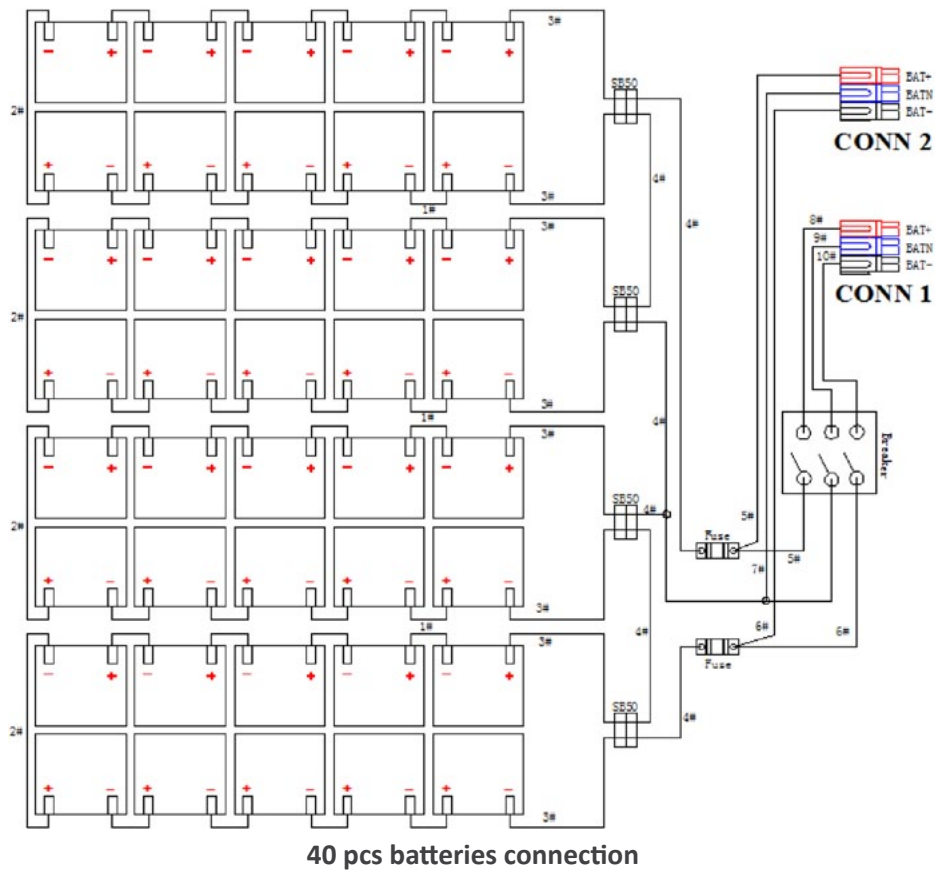

After the battery installation and connection done, check if BAT+ to N & N to BAT- voltages are correct with multi-meter or other equipment. Install the cover if the voltages are correct.

Note: Battery “+” “-” poles cannot be reversed, also cannot short the battery “+” “-” poles, otherwise batteries would be damaged or other accidents would happen. Don’t touch the battery “+” “-” poles at the same time. It’s better only single man make the operation.

Fuse in Battery Pack

The battery pack has 2 x fuses inside as shown in below picture.

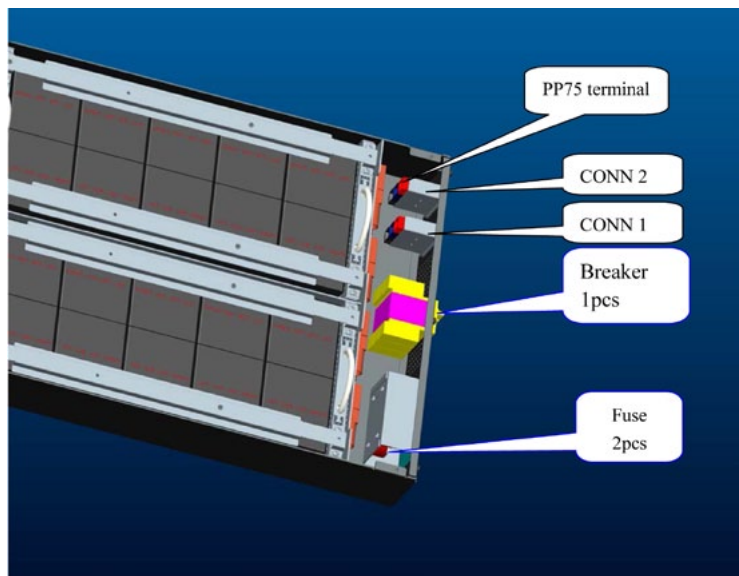

4 Post Rail Mounting

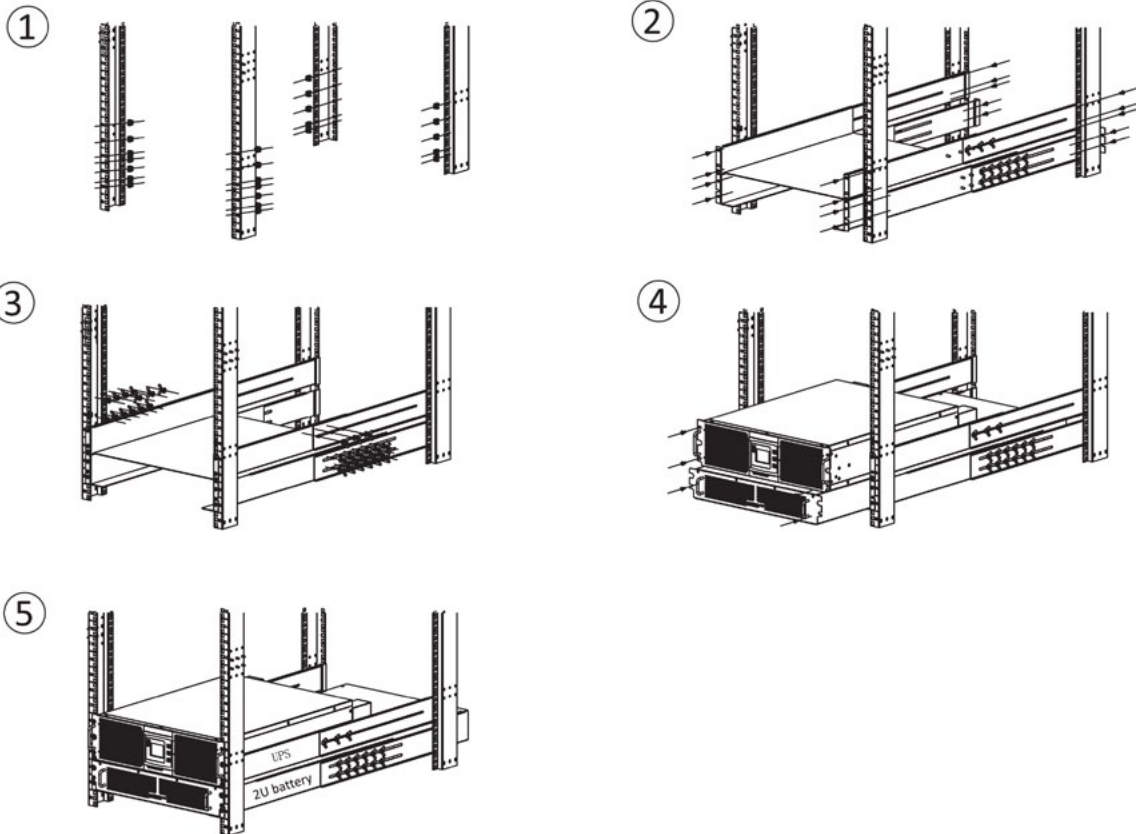

Multiple Battery Pack Connections



CAUTION!

Ensure correct polarity of the battery string series connection. DO NOT mix batteries with different capacity or different brands, or new or old batteries.



WARNING!

ENSURE CORRECT POLARITY OF STRING END CONNECTIONS TO THE BATTERY CIRCUIT BREAKER, AND FROM THE BATTERY CIRCUIT BREAKER TO THE UPS TERMINALS (I.E. (+) TO (+) / (-) TO (-) / (N) TO (N)). DISCONNECT ONE OR MORE BATTERY CELL LINKS IN EACH TIER. DO NOT RECONNECT THESE LINKS AND DO NOT CLOSE THE BATTERY CIRCUIT BREAKER UNLESS ALL CONNECTIONS ARE PROPERLY CHECKED AND APPROVED.

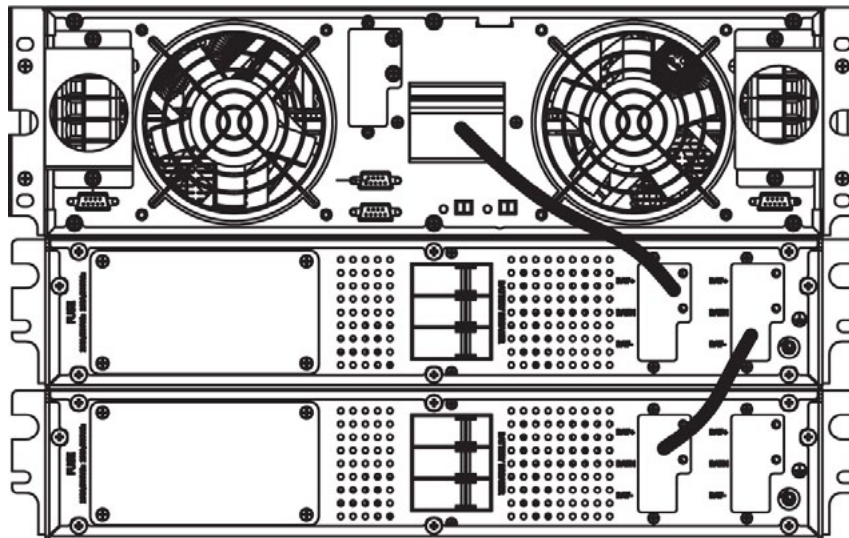

R91-20K to BP-XR2U480A battery connection

Installation and Setup

Note: Before installation, please inspect the unit. Be sure that nothing inside the package is damaged. Please keep the original packing material in a safe place for future use.

Unpacking & Inspection

Attention: Any damage to packing should be noted at the time of receipt with the delivery carrier

Remove the shelf kit, battery enclosure, and battery modules from the packaging.

Note: The battery modules are very heavy, be cautious when unpacking and lifting the unit to avoid injury.

Selecting Installation Position

It is necessary to select a proper environment to install the unit, in order to minimize the possibility of damage to the battery system and extend the life of the batteries. Please follow the instructions below:

1. Do not block the air-flow to the ventilation openings of the unit.
2. Please ensure the installation site environmental conditions are in accordance with the unit's working specifications to avoid overheat and excessive moisture.
3. Do not place the unit in a dusty or corrosive environment or near any flammable objects.
4. This unit is not designed for outdoor use.

Enclosure Installation

Note: Shelf kit must be installed per battery enclosure.

1. Add moveable cage nuts to desired front and rear location for shelf kit and battery enclosure.
2. Attach shelf kit into the rack with screws at front and rear.
3. Slide the battery enclosure from the front into the rack onto the shelf kit.
4. Fasten front and rear mounting ears to battery enclosure
5. Attach the mounting ears of the battery enclosure into the shelf kit and rack with screws at front and rear.

Battery Module Installation

1. Remove front cover from the battery enclosure.
2. Slide in battery modules.
3. Secure front cover in place.
4. Remove UPS connection cover from battery pack and connect the Anderson connector to UPS.

Operation

Operation Modes

The UPS is a double-conversion online UPS that may operate in the following alternative modes.

Normal Mode

The rectifier / charger derives power from the AC input utility and supplies DC power to the inverter while floating and boost charging the battery simultaneously. The inverter then converts the DC power to AC power and supplies the load.

Battery Mode (stored energy mode)

If the AC input utility power fails, the inverter, which is operating from power supplied by the battery, supplies the critical AC loads with power from the batteries. There is no power interruption to the critical load. The UPS will automatically return to Normal Mode when AC input utility recovers.

Bypass Mode

If the inverter is not functioning correctly, or if an overload occurs, the static transfer switch will be activated to transfer the load from the inverter supply to bypass supply without interruption to the critical load. In the event that the inverter output is not synchronized with the bypass AC source, the static switch will perform a transfer of the load from the inverter to the bypass with power interruption to the critical AC loads. This is to avoid paralleling of unsynchronized AC sources. This interruption is programmable but typically set to be less than one electrical cycle (less than 15ms at 50Hz or less than 13.3ms at 60Hz).

ECO Mode

When the UPS is in AC Model and the requirement to the load is not critical, the UPS can be set to ECO Mode in order to increase the efficiency of the power supplied. In ECO Mode, the UPS works in line-interactive mode, so the UPS will transfer to bypass utility. When the AC is out of the set window, the UPS will transfer from bypass to inverter and supply power from the batteries, with the LCD displaying all related information.

Parallel Redundancy Mode (system expansion)

To achieve higher capacity and / or increase reliability, the output of up to four (4) UPS modules can be programmed to operate in parallel, with the built-in parallel controller in each UPS ensuring automatic load sharing.

Turn On / Off the UPS

Connecting with Utility



CAUTION!

MAKE SURE PROPER GROUNDING IS IN PLACE.

- Set the Battery Breaker to the “ON/Closed” position according to the user manual.
- Switch “ON/Closed” the Utility Breaker
- Switch “ON/Closed” the UPS



CAUTION!

Check to see if the load is safely connected to the output of the UPS. If the load is not ready to receive power from the UPS, make sure that it is safely isolated from the UPS output terminals.

The internal fan of the UPS will start spinning; the UPS will perform self-diagnostics. The UPS then goes to bypass, bypass LED turn Amber, the inverter is now starting. When the inverter is checked “normal”, the UPS goes to Normal Mode (Green LED) and the load is supplied power by the inverter.

Cold Start Procedure



CAUTION!

Follow these procedures when there is an input AC Utility Failure but the batteries are normal.

- Turn on the battery switch.
 - » The battery will feed the Auxiliary power board.
- Trigger the Cold Start Buttons of the modules respectively using the ON BUTTON shown in the above diagram.
 - » When battery is normal, the rectifier starts operation. 30 seconds later the inverter starts and operates, INV and Output light up.



CAUTION!

Wait for approximately 30 seconds before pressing the ON BUTTON.

Inverter Off

When the Utility is normal, press OFF BUTTON for approximately 3 seconds and lift off and you will hear a beep. The INVERTER LED will extinguish, the BYPASS LED will be illuminated, then the UPS turns to bypass supply.

Disconnecting from Utility



CAUTION!

This procedure should be followed to completely shut down the UPS and the LOAD. After all power switches, isolators, and circuit breakers are opened, there will be no output power from the UPS.

- After the inverter is off, turn the Utility and Battery breakers to “OFF”. The LCD display will extinguish completely and the fan stops spinning in 60 seconds. If there are external battery packs connected, turn the Battery breakers on each battery pack to the “OFF/Open” position.

**WARNING!**

Wait about 5 minutes for the internal DC bus bar capacitors to be completely discharged.

Computer Access

- Connect one end of the RS232 communications cable to a computer and the other end to the RS232 port on the UPS
- Open the software Muser4000, and choose “system” button

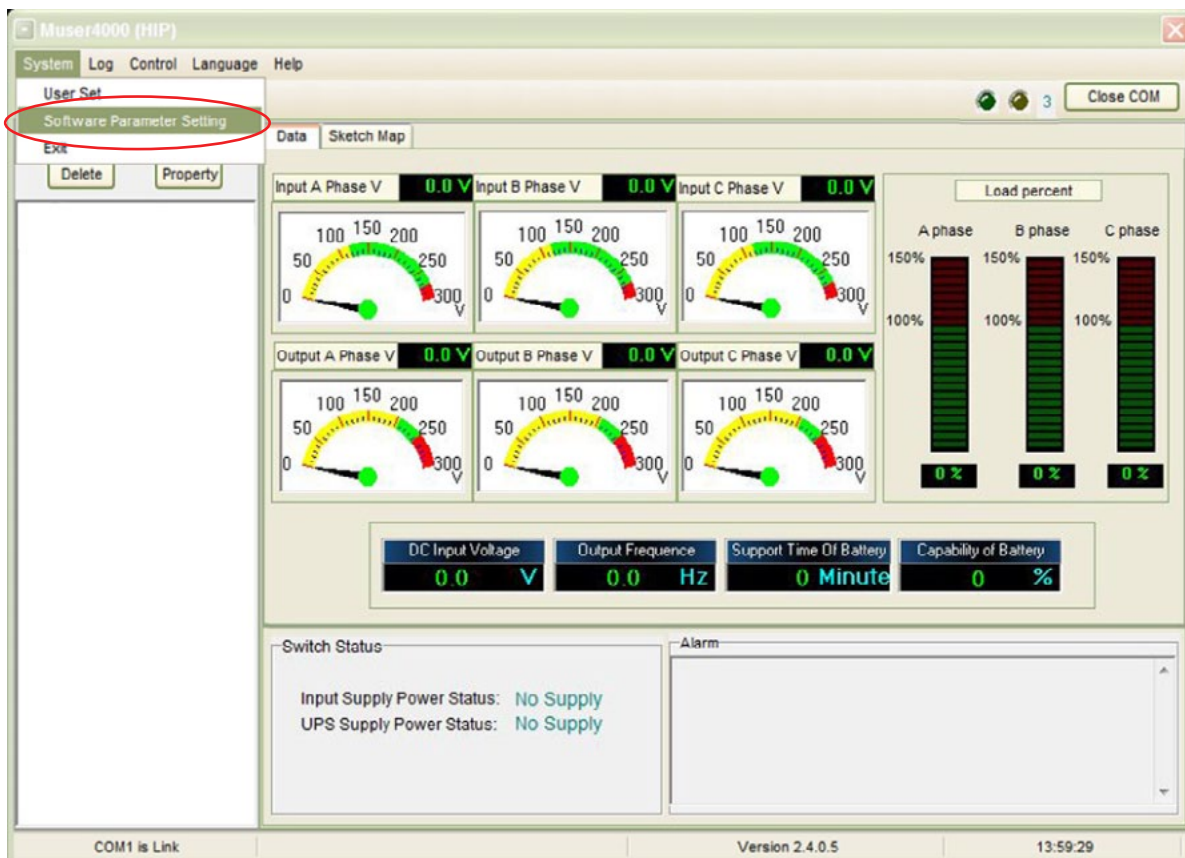

- Choose **“Software Parameter Setting”** and set selections as shown below and then save settings
 - o COM = COM1
 - o Baud Rate = 9600
 - o Protocol = HIP

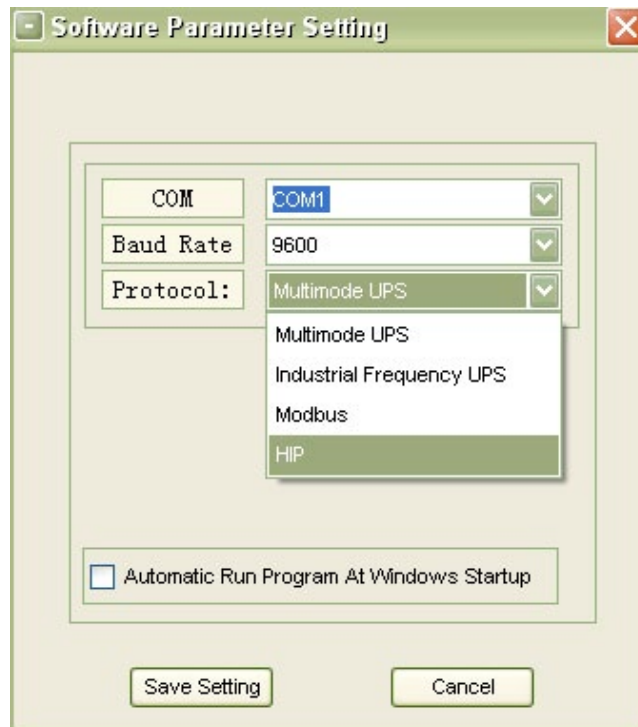

- On the main page of Muser4000, choose the **“Append”** button, place the UPS name into **“Equipment Name”**, and UPS ID address into **“Equipment address”**. Choose the **“Append”** button, then the connection between UPS and computer is complete.



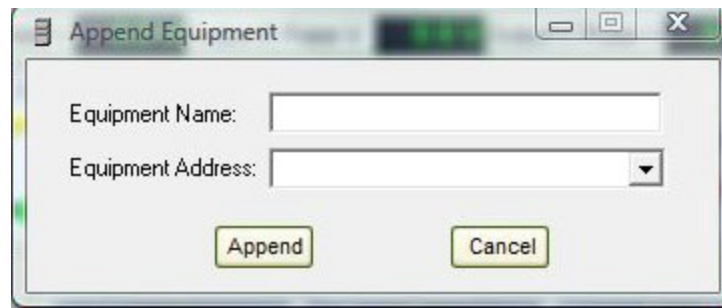

Parallel Setting

- Connect the UPS with a computer. Power ON the UPS.
- Open Muser4000 software and choose "System" > "User Set"



- Select **“Set”** at **“User Set”** window

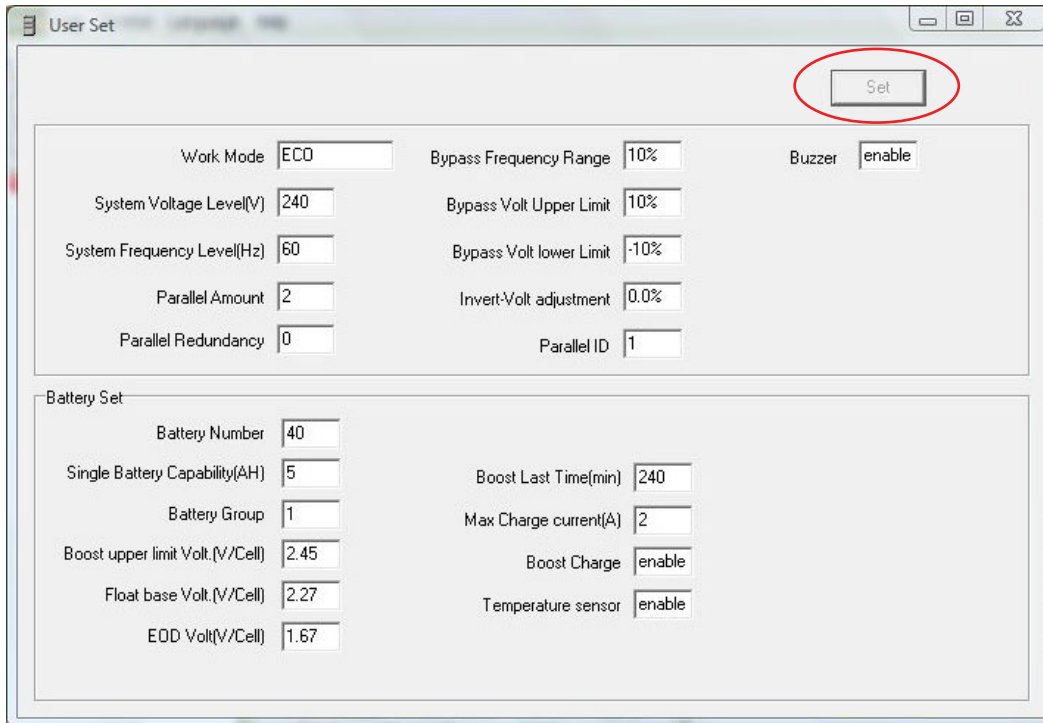

CAUTION!

When powered by inverter, it is necessary to turn off the inverter before setting the voltage and frequency level in PC

- Once **“Set”** is selected, you will be prompted to enter a password corresponding with which battery pack is being used with the UPS. Reference the battery pack manual for corresponding password.

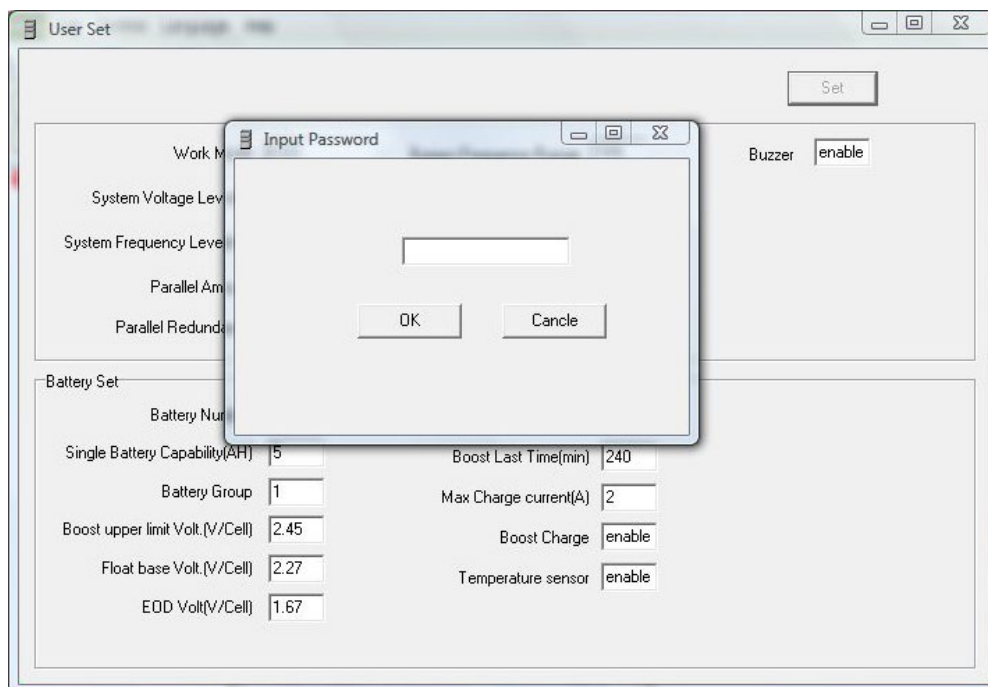

- At the window of “Data Set”, select “Work Mode” with “Parallel” for the Value, then select “Set” as shown in the figure below. If the UPS “beeps” it means the setting is correct.

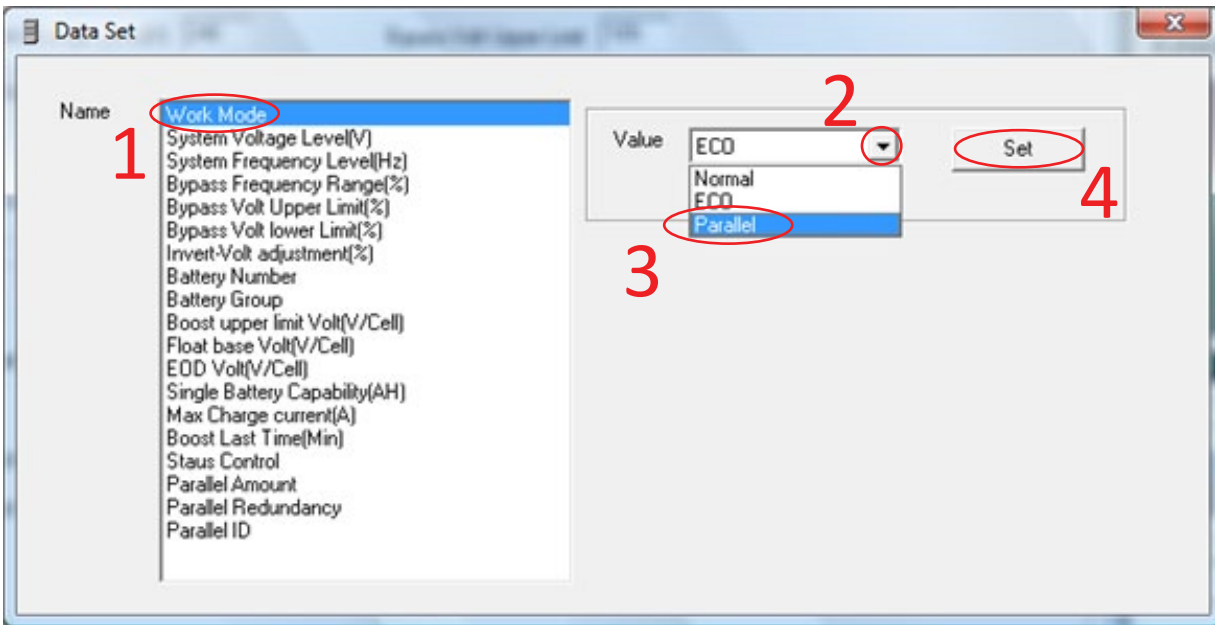

- At the window of “Data Set”, select “UPS ID”, enter the Value for the parallel UPS ID at the right side, then select “Set” as shown in the figure below. If the UPS “beeps” it means the setting is correct.

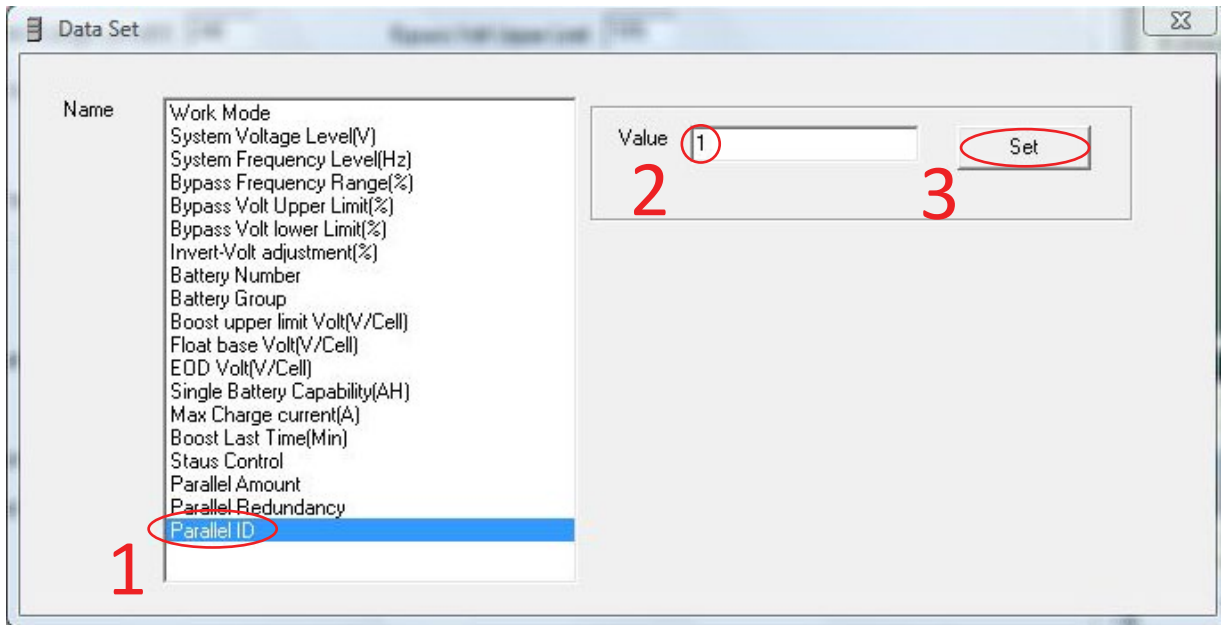



CAUTION!

After changing the parallel system ID, the connection between Muser4000 and equipment might be interrupted. If this occurs, re-connect in accordance with the instructions described earlier in this manual.



CAUTION!

Parallel cable cannot be connected when setting the parallel parameters

- After setting the UPS's that need to be paralleled, power OFF all the UPS's. Connect all the UPS's according to "parallel cable installation", and then power ON the UPS's.

Communication Port Definitions (RS232, RS485)

Definition of the Port

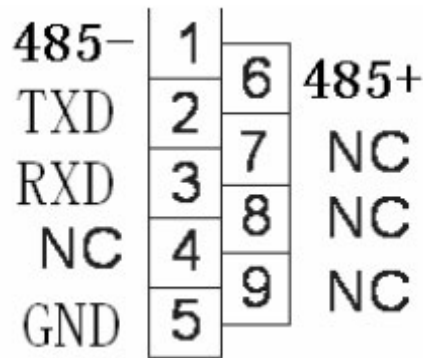

Connection between PC RS232 port and UPS RS232 port

PC RS232 port	UPS RS232 port	Description
Pin 2	Pin 2	UPS send, PC receive
Pin 3	Pin 3	PC send, UPS receive
Pin 5	Pin 5	Ground

Connection between the computer RS485 port and UPS RS485 port

PC (DB9 male)	UPS (DB9 female)	Description
Pin 1	Pin 1	485 "-"
Pin 6	Pin 6	485 "+"

Available function of RS232

- Monitor UPS power status
- Monitor UPS alarm information
- Monitor UPS running parameters
- Timing Off / On setting

RS-232 communication data format

Baud rate = 9600bps

Byte length = 8bit

End bit = 2bit

Parity check = none

LCD Display

System LCD Diagram

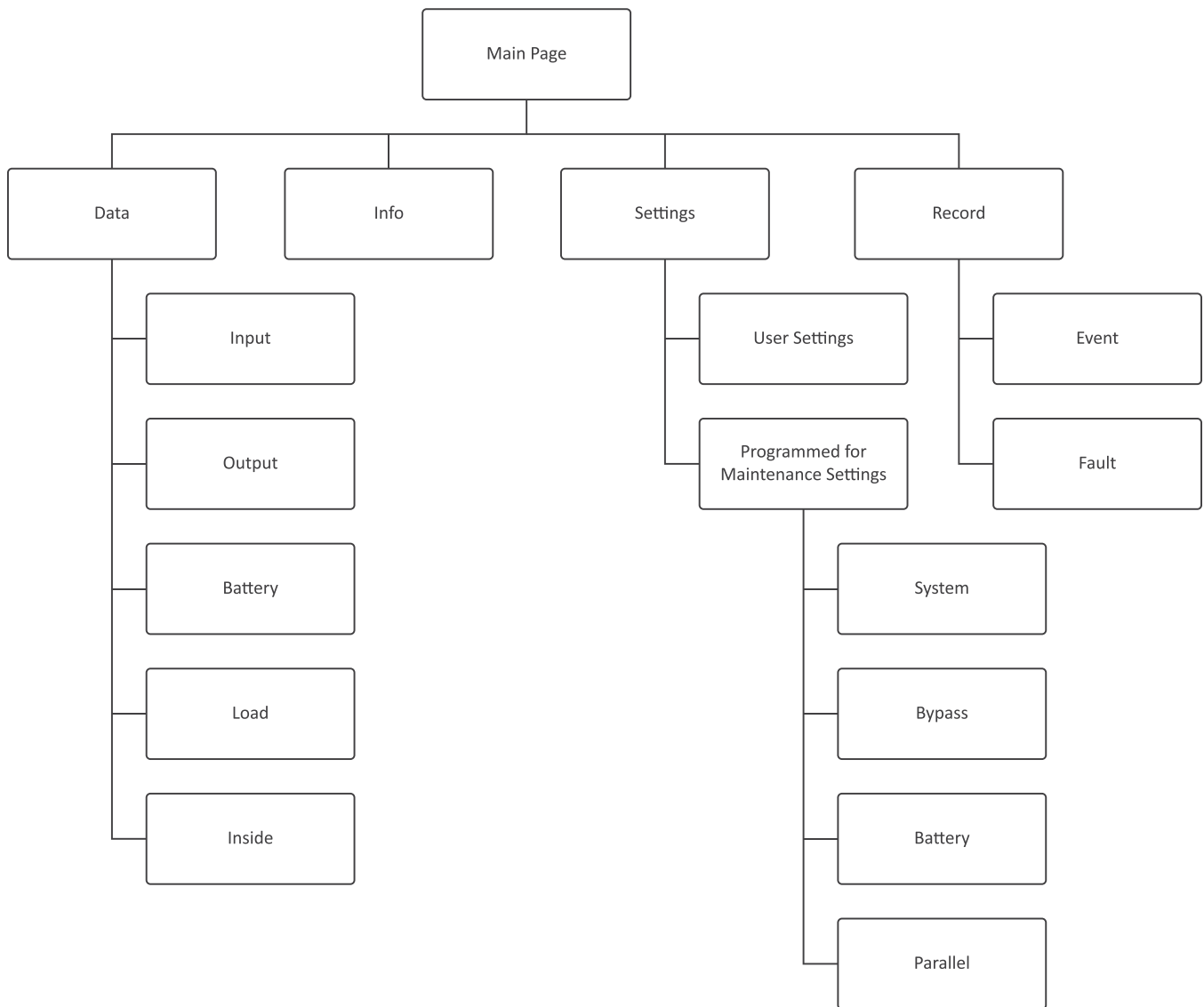

System LCD Description

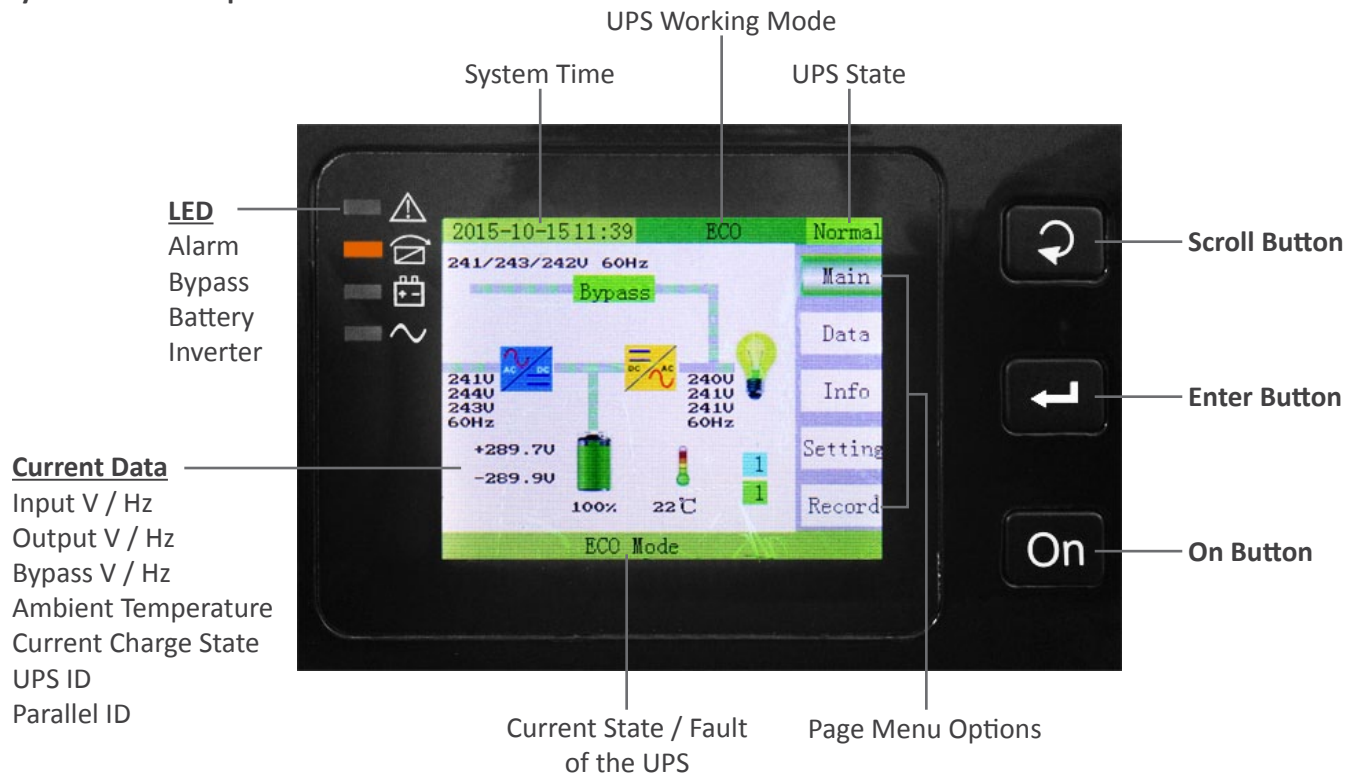

CAUTION!

The display provides more functions than those described in this manual.

Data

Press "Scroll" Button, the UPS goes to the next screen as shown below.

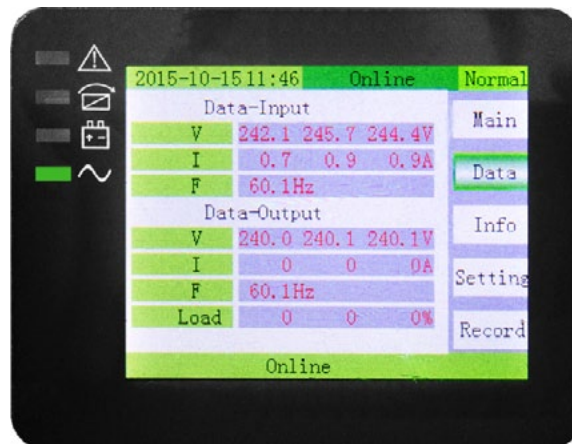

Displays: Phases A, B, and C (L1,L2, and L3) Input/Output Voltage, Current, and Frequency and Output load percentage.

Data - Input

Press "Enter" Button, the UPS goes to the next screen as shown below.

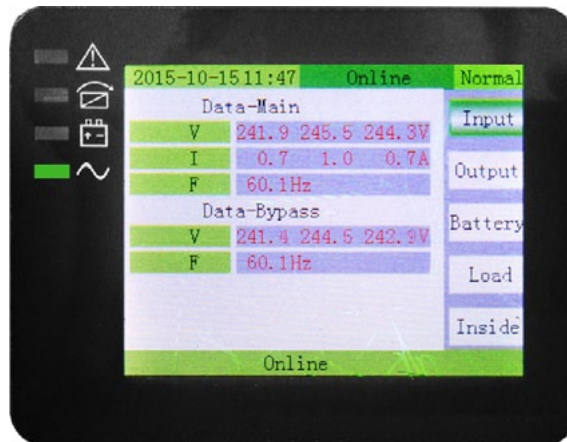

Displays: Main Voltage, Current, and Frequency. Bypass Voltage and Frequency

Data - Output

Press "Scroll" Button, the UPS goes to the next screen as shown below.

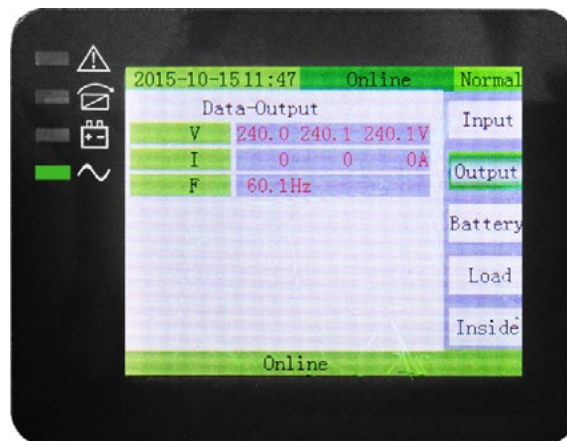

Displays: Output Voltage, Current, and Frequency

Data - Battery

Press "Scroll" Button, the UPS goes to the next screen as shown below.

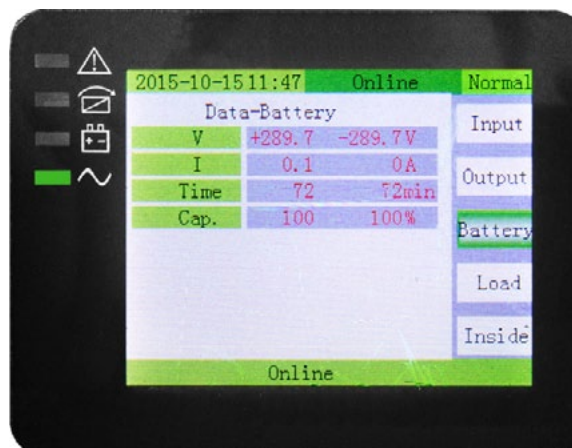

Displays: Battery Voltage, Current, Battery Run Time, and Battery Capacity

Data - Load

Press "Scroll" Button, the UPS goes to the next screen as shown below.

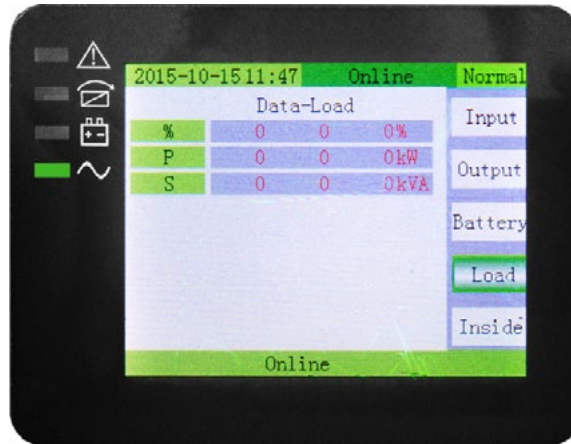

Displays: Phases A, B, and C (L1, L2, and L3) Load Percentage, kW, and kVA

Data - Inside

Press "Scroll" Button, the UPS goes to the next screen as shown below.

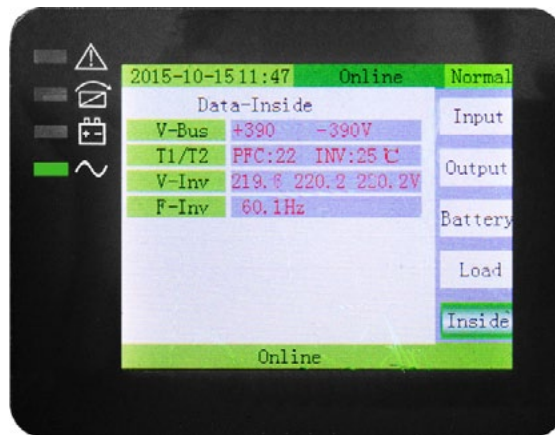

Displays: V-Bus, T1/T2, V-INV, and Frequency

Information

Hold "Scroll" Button for 3 seconds to exit Data sub-pages. Press "Scroll" Button, the UPS goes to the next screen as shown below.

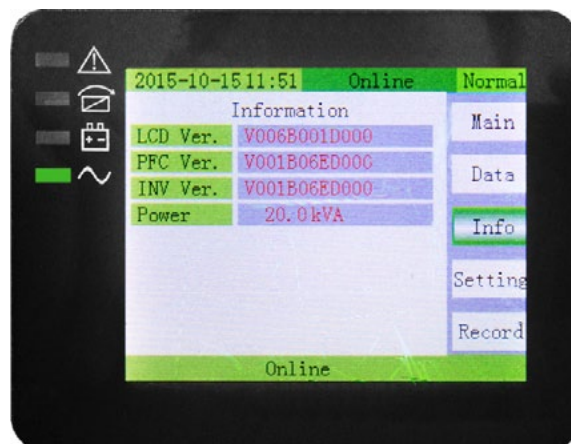

Displays: LCD, PFC, INV Versions, and Rated Power for UPS

Setting

Press "Scroll" Button, the UPS goes to the next screen as shown below.

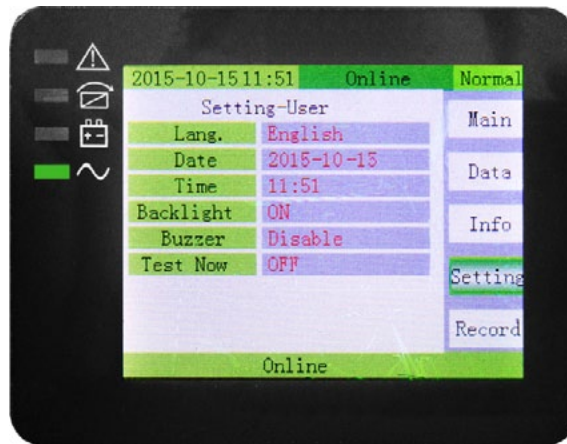

Displays: User Settings - Language, Date, Time, Backlight, Buzzer, and Battery Test options. View User Settings and System Parameter Settings section for instructions on making selections.

Record

Press "Scroll" Button, the UPS goes to the next screen as shown below.

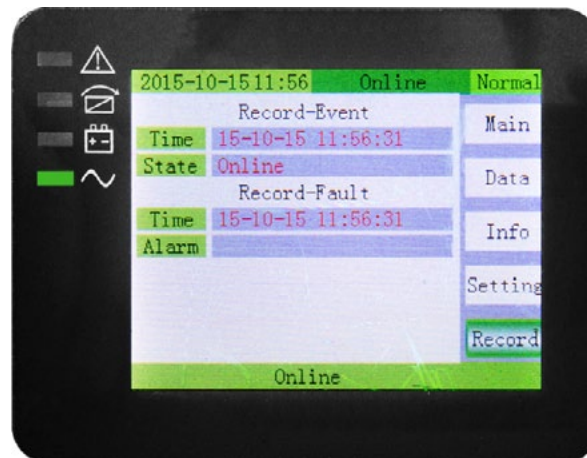

Displays: Latest Recorded Event and Fault with time stamp and description.

Record - Event

Press "Enter" button and use "Scroll" button to highlight most recent event or fault recorded. Press "Enter" button, the UPS goes to the next screen as shown below.

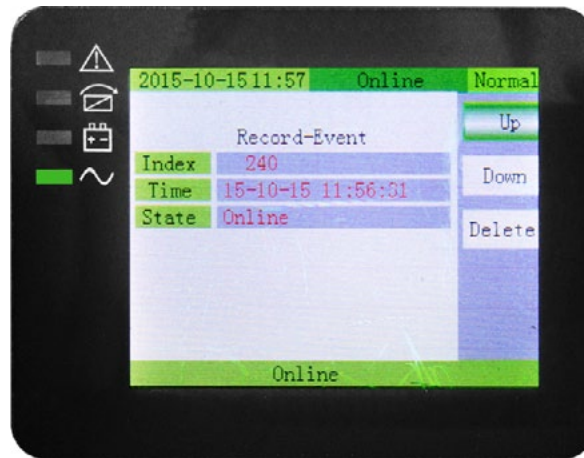

Displays: Index, Time of recording, and description. User is able to view most current and past event or fault.
*Note if user selects delete, all event or fault recordings will be deleted.

User Settings and System Parameter Settings

The setting function is controlled by 2 buttons (Scroll and Enter):

- Scroll – Moves through parameters and adjust values
- Enter – Goes into setting pages and confirms selections

Enter System Parameter Setting Mode: Hold "Scroll" and "Enter" simultaneously for 3 seconds. See below for Maintenance password page. Maintenance password: 1121

Exit Setting Mode, Sub-Pages, Parameter fields, and Cancel Selection: Hold "Scroll" button for 3 seconds

Saving Settings: When desired parameter value is highlighted hold "Enter" button for 3 seconds. Confirm change was made.

Maintenance Password Page

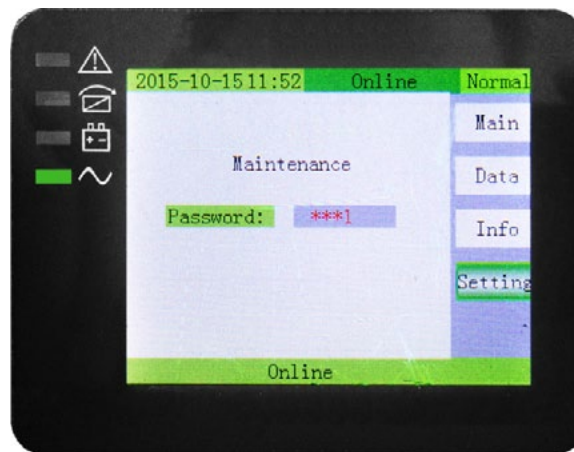

Once Maintenance Password is entered, press the "Enter" button and the UPS goes to the next screen as shown below.

Setting - System

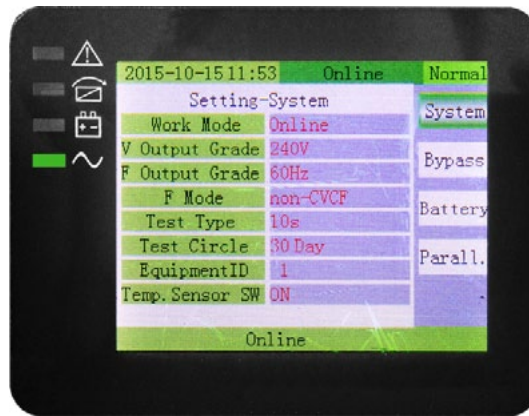

Displays: System Parameter Settings Page.

The following parameters can be adjusted:

System Setting	Range	Default
Working Mode	Online, ECO, Parallel	Online
V Output Grade*	220V, 230V, 240V	240V
F Output Grade**	50Hz, 60Hz	60Hz
F Mode	non-CVCF, CVCF	non-CVCF
Test Type	OFF, 10s, 10min, EOD	OFF
Test Cycle	1- 60 Day	30 Day
Equipment ID	1-16	1
Temperature Compensation	Enable, Disable	Enable

* Need to be in Bypass

** If not in Bypass Output will drop load

Setting - Bypass

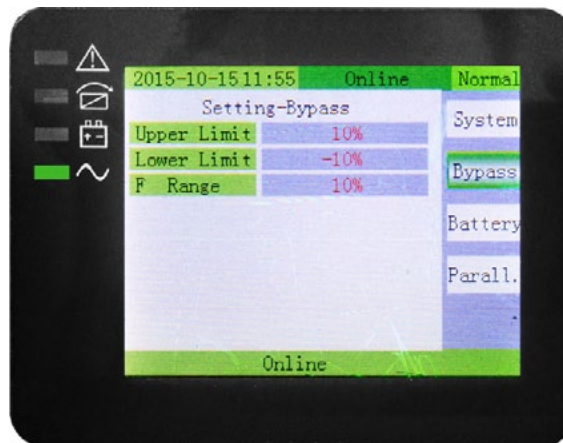

Displays: Bypass Parameter Settings Page.

The following parameters can be adjusted:

Bypass Setting	Range	Default
Upper Limit	10 & 15%	15%
Lower Limit	-45, -30, -20%	-20%
F Range	1, 2, 4, 5, 10%	10%

Setting - Battery

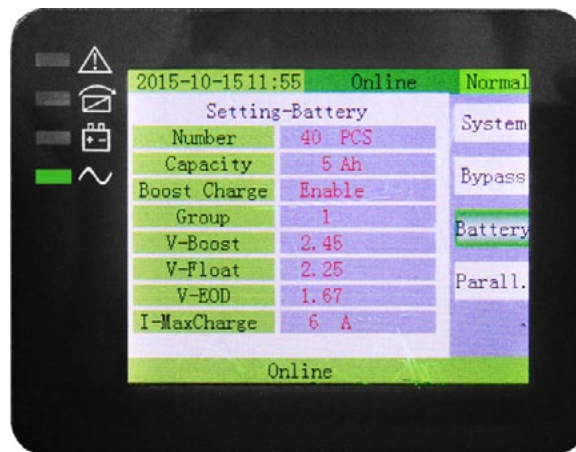

Displays: Battery Parameter Settings Page.

The following parameters can be adjusted:

Battery Setting	Range	Default
Number (Battery Cells Per String)	192, 204, 216, 228, 240	240
Capacity (Battery Rating AH)	7-200	7
Boost Charge	Enable/Disable	Enable
Group (Battery Strings Qty)	1 to 8	1
V-Boost (Boost Upper Limit Voltage V/cell)	2.41 - 2.50	2.45
V-Float (Float Base Voltage V/cell)	2.20 - 2.29	2.27
V-EOD (EOD Voltage V/Cell)	1.55 - 1.75	1.67
I-MaxCharge (Max Charging Current)	1 - 6	2

Setting - Parallel

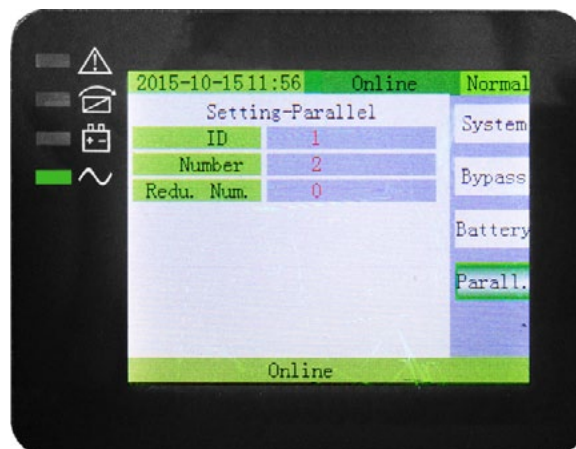

Displays: Parallel Parameter Settings Page.

The following parameters can be adjusted:

Parallel Setting	Range	Default
ID	1 to 4	1
Number	1 to 8	2
Redundancy Number	0 to 1	0

Options



CAUTION!

For network management configuration and use, refer to the separate user manual - Network Management Card with Environmental Monitor, which is shipped with the SNMP card.

SNMP Card: external SNMP optional

- Connect the external SNMP adapter to the SNMP port indicated
- Tighten the screws

The slot called SNMP supports the Megatec protocol. We advise SNMP-R90 as a tool to remotely monitor and manage any UPS system.

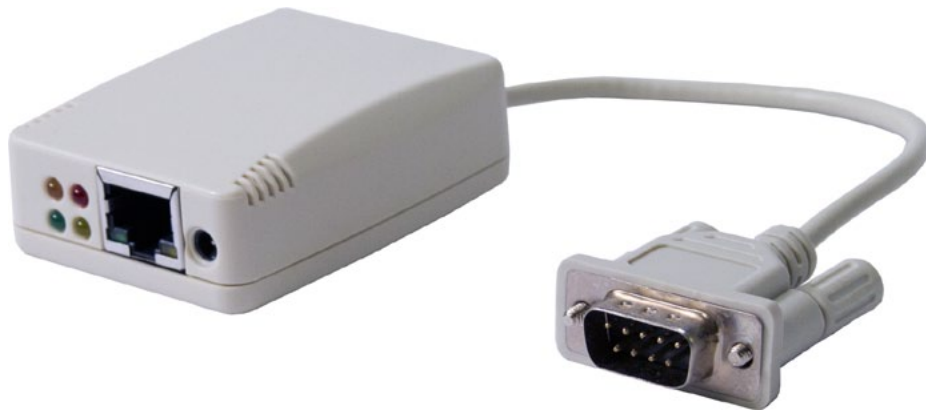

SNMP-R90 External Smp Card

Troubleshooting

No.	PROBLEM	POSSIBLE REASON	SOLUTION
1	Utility connected but the UPS cannot power ON	Input power supply is not connected.	Measure if the UPS input voltage / frequency are within the required range per specification. Check if all modules input switches are turned on.
		Input voltage low	
		The input switch of the module is not switched on	
2	Utility normal but Utility LED does not light, and the UPS operates at battery mode	The input breaker of the modules are not switched on; input cables are not properly connected	Switch on the input breaker. Make sure the input cable is properly connected.
3	The UPS does not indicate any failure, but the output does not have voltage	Output cable is not properly connected	Make sure the output cable is properly connected
4	Battery LED is flashing but no charge voltage and current	Battery breaker does not switch on, or batteries are damaged, or battery is reverse connected.	Switch on the battery breaker. If batteries are damaged, replace the entire set of batteries. Connect the battery cables correctly.
		Battery number and capacity are not set correctly	Go to the LCD display setting of the battery number and capacity, and set with correct data.
5	Audible beep every 0.5 seconds, Inverter LED flashes, and LCD displays "Output Overload"	Overload	Remove load to < 95% to clear alarm
6	The UPS only works on bypass	The UPS is set to ECO Mode or the transfer times to Bypass Mode are limited	Set the UPS working mode to Single Module type (non-parallel) or to reset the times of transfer to bypass or re-start the UPS
7	Cannot Cold Start	Battery breaker is not properly closed or battery capacity is low	Close the battery breaker; Recharge the batteries
15	Buzzer sounds continuously, Fault LED is illuminated and the related code of "Rectifier / Inverter Out of Order" or "Output Out of Order" shows in the LCD display	UPS has failed	Contact dealer or distributor for service and repair

Specifications

MODEL NUMBER		R91-20K
CAPACITY	Power rating	20kVA/18kW
INPUT	Phase	Three-phase + neutral + ground
	Voltage range	210–478VAC*
	Frequency	40–70Hz
	Power factor	≥ 0.99
	Rectifier power walk-in	1–20 seconds (programmable)
OUTPUT	Voltage	415/240VAC, 380/220VAC, 400/230VAC (selectable)
	Overload protection	110% for 60 min; 125% for 10 min; 150% for 1 min; > 150% immediate
	Voltage regulation	± 2%
	Efficiency	Online mode up to 94%; ECO mode up to 99%
UPS PHYSICAL	Dimensions (W x D x H)	443 x 580 x 131 mm (17.4 x 22.8 x 5.2 in)
	Unit / shipping weight	31 kg (68.4 lbs) / 42 kg (92 lbs)
ENVIRONMENT	Operating temperature	0–40°C (32–104°F)
	Altitude	11,500 ft above sea level
	Humidity	0–95% non-condensing
	Storage temperature	-25–55°C (-13–131°F) non-condensing (UPS)
APPROVALS	UL 1778, FCC A (pending)	
WARRANTY	3 years electronics (USA and Canada)	
COMMUNICATIONS INTERFACE	RS232, RS485, EPO, parallel port, external Web/SNMP (optional)	
INCLUDED IN BOX	Shelf kit, local monitoring software	
AVAILABLE OPTIONS	IEC 60309 32A input/output cord kit, Web/SNMP card, maintenance bypass	

*Online Mode. Depending on load level

Shipping List

R91-20K UPS

1. Software CD
2. Shelf with mounting hardware
3. Manual

Obtaining Service

If the UPS requires Service:

1. Use the TROUBLESHOOTING section in this manual to eliminate obvious causes.
2. Verify there are no circuit breakers tripped.
3. Call your dealer for assistance. If you cannot reach your dealer, or if they cannot resolve the problem, call Xtreme Power Conversion Corp Technical Support at 800.582.4524. Technical support inquiries can also be made at support@xpcc.com. Please have the following information available BEFORE calling the Technical Support Department:
 - Your name and address.
 - The serial number of the unit.
 - Where and when the unit was purchased.
 - All of the model information about your UPS.
 - Any information on the failure, including LED's that may or may not be illuminated.
 - A description of the protected equipment, including model numbers if possible.
 - A technician will ask you for the above information and, if possible, help solve your problem over the phone. In the event that the unit requires factory service, the technician will issue you a Return Material Authorization number (RMA).

If you are returning the UPS to Xtreme Power for service, please follow these procedures:

1. Pack the UPS in its original packaging. If the original packaging is no longer available, ask the Technical Support Technician about obtaining a replacement set of packaging material. It is important to pack the UPS properly in order to avoid damage in transit. Never use Styrofoam beads for a packing material.
2. Include a letter with your name, address, daytime phone number, RMA number, a copy of your original sales receipt, and a brief description of the problem.
3. Mark the RMA number on the outside of all packages. Xtreme Power cannot accept any package without the RMA number marked on the outside of the boxes.
4. Return the UPS by insured, prepaid carrier to the address provided by the Technician.
5. Refer to the Warranty statements in this manual for additional details on what is covered.

Xtreme Power Conversion Limited Warranty

USA

Xtreme Power Conversion (XPC) Corporation warrants Xtreme Power Conversion equipment, when properly applied and operated within specified conditions, against faulty materials or workmanship for a period of **three years for R91-Series products** from the date of purchase. For equipment sites within the United States and Canada, this warranty covers repair or replacement, at the sole discretion of XPC Corporation. The customer is responsible for the costs of shipping the defective product to XPC Corporation. XPC Corporation will pay for ground shipment of the repaired or replacement product. This warranty applies only to the original purchaser.

EMEA

Xtreme Power Conversion (XPC) Corporation warrants Xtreme Power Conversion equipment, when properly applied and operated within specified conditions, against faulty materials or workmanship for a period of **two years for R91-Series products** from the date of purchase. For warranty units, an (RMA) must be requested for all claims. XPC will honor warranties at the sole discretion of XPC Corporation after units have been evaluated.

If equipment provided by XPC Corporation is found to be **Dead-on-Arrival (DOA)**, the customer must request and received a **Return Material Authorization (RMA)** number. DOA equipment is defined as equipment that does not properly function according to user documentation when initially received and connected in conjunction with proper procedures as shown in the user documentation or via support provided by XPC Corporation personnel or authorized agents.

This warranty shall be void if (a) the equipment is repaired or modified by anyone other than XPC Corporation or a XPC Corporation approved third party; (b) the equipment is damaged by the customer, is improperly used or stored, is subjected to an adverse operating environment, or is operated outside the limits of its electrical specifications; or (c) the equipment has been used or stored in a manner contrary to the equipment's operating manual, intended use or other written instructions. Any technical advice furnished by XPC Corporation or a XPC Corporation authorized representative before or after delivery with regard to the use or application of Xtreme Power Conversion equipment is furnished on the basis that it represents XPC Corporations best judgment under the situation and circumstances, but it is used at the recipient's sole risk.

EXCEPT AS STATED ABOVE, XPC Corporation DISCLAIMS ALL WARRANTIES, EXPRESSED OR IMPLIED, INCLUDING WARRANTIES OF MERCHANTABILITY AND FITNESS FOR A PARTICULAR PURPOSE.

EXCEPT AS STATED ABOVE, IN NO EVENT WILL XPC Corporation BE LIABLE FOR DIRECT, INDIRECT, SPECIAL, INCIDENTAL, OR CONSEQUENTIAL DAMAGES ARISING OUT OF THE USE OF Xtreme Power Conversion EQUIPMENT, including but not limited to, any costs, lost profits or revenue, loss of equipment, loss of use of equipment, loss of software, loss of data, cost of substitutes, or claims by third parties. Purchaser's sole and exclusive remedy for breach of any warranty, expressed or implied, concerning Xtreme Power Conversion equipment, and the only obligation of XPC Corporation under this warranty, shall be the repair or replacement of defective equipment, components, or parts; or, at XPC Corporations sole discretion, refund of the purchase price or substitution of an equivalent replacement product.