



**VALVE REGULATED
LEAD ACID BATTERY (V.R.L.A.)**



**ADVANCED ABSORBED GLASS
MAT TECHNOLOGY (A.G.M.)**



**LONG DURATION BATTERIES
DESIGNED FOR MAXIMUM LIFE**



10 VOLT CONFIGURATION AVAILABLE !

Features

- Flame-retardant polypropylene case and cover compliant with UL94 V-0 with an Oxygen Limiting Index of greater than 28%.
- Gas recombination greater than 99%.
- Operates at a low internal pressure.
- Never needs watering, minimal maintenance.
- 99.7% pure lead, calcium alloy grids.
- Shock absorbent thick wall polypropylene cases.
- Cold forged non-porous terminal bushings, eliminate post leakage.
- Thermally welded case to cover bond, eliminates both acid and electrical leaks.
- Over-sized, through the partition inter-cell welds provide low resistance connections, with minimal power loss.
- Flame arresting, low pressure safety release venting system for individual cells, recognized per U.L. 924.
- Measured high vacuum acid fill, reduces electrical variability between cells.
- 100% recyclable materials.

Options

- Terminal covers.
- Inter-connecting battery cables.
- Custom wire harnesses.

Specifications

Cells per unit	6
Nominal voltage	12
Terminal type	Threaded copper insert
Short circuit current	2733 amps
Impedance @ 77°F 25°C	5.05 milliohms
Weight lbs / kgs	35.3 / 16.0
Electrolyte (S.G.)	1.300
Capacity @ 77°F (25°C)	45 AH (8 hrs) to 1.75 V.P.C.
Ideal operating temperature range	+68°F (+20°C) to +77°F (+25°C)
Extended operating temperature range	Discharge: -40°F (-40°C) to +140°F (+60°C) Charge: -4°F (-20°C) to +122°F (+50°C)
Float Voltage	13.5 to 13.8 @ 77°F (25°C)
Recommended maximum charging current	C/4 amperes at 100% discharge Unlimited at partial discharge.
AC ripple from charging source	1.5% peak to peak of float
Storage period without recharge	6 months at 77°F (25°C)

No transport restrictions

- Surface transport. Classified as non-hazardous material as relates to DOT-CFR Title 49 part 171-189.
- Maritime transport. Non hazardous as per IMDG amendment 27.
- Air transport. Non hazardous complies with IATA / ICAO, special provision A67.

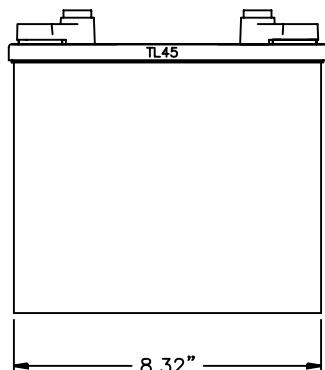

FRONT VIEW

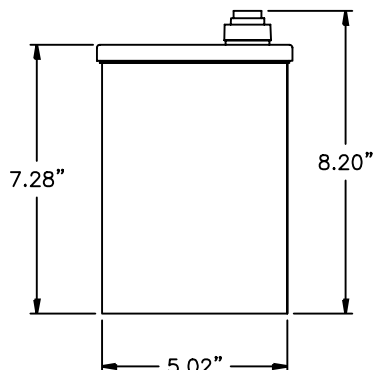

END VIEW

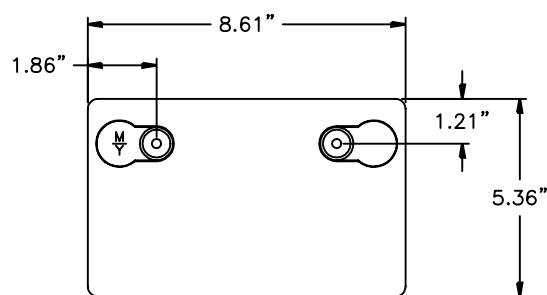

TOP VIEW

POWER BATTERY offers an extensive line of pre-wired and fused battery cabinets complete with UL and CUL approval. Standard and custom DC voltages complete with breakers and chargers are available.

Battery Cabinet Systems (pre-wired with TL-1245 batteries)

Battery cabinet model	Maximum # of batteries	Dimensions					
		inches			millimeters		
		H	W	D	H	W	D
KS4	2	15.75	11.5	19.0	400	292	483
KS5	4	15.75	15.0	25.0	400	381	635
KS6	8	17.75	16.0	34.5	451	406	876
KS7	16	37.25	16.0	34.5	946	406	876
CR1	20	43.0	24.0	32.5	1092	610	826
CR3	36	43.0	40.0	32.5	1092	1016	826
CR6	54	60.0	40.0	32.5	1524	1016	826

Hours discharge rates in constant current (Amperes) and constant power (Watts) @ 77°F (25°C)

Volts per cell		1	2	3	4	5	6	7	8	9	10	12	24	48
1.75	Amps	31.4	18.2	13.3	10.4	8.57	7.30	6.36	5.65	5.09	4.61	3.94	2.12	1.14
	* Watts	372	224	163	129	108	93.2	81.8	72.7	65.3	59.2	49.9	26.5	14.5
1.80	Amps	30.9	18.1	13.1	10.2	8.43	7.20	6.29	5.59	5.04	4.59	3.90	2.10	1.11
	* Watts	368	216	158	126	105	89.9	78.5	69.6	62.5	56.8	48.1	25.7	14.0
1.85	Amps	29.7	17.6	12.7	9.89	8.16	6.97	6.09	5.41	4.87	4.43	3.77	2.02	1.04
	* Watts	356	208	152	120	100	86.0	75.2	66.8	60.0	54.6	46.3	24.7	13.1
1.90	Amps	27.3	16.4	11.9	9.33	7.69	6.55	5.70	5.05	4.52	4.09	3.45	1.87	0.99
	* Watts	334	193	140	111	93.5	80.5	71.2	63.8	57.4	52.2	44.2	23.6	12.6

* For 10 Volt models reduce the Watts by 18%

U.S.A.
Power Battery Company, Inc.
 25 McLean Blvd.
 Paterson, N.J. 07514-1507
 Phone: (973) 523-8630
 Fax: (973) 523-3023
 E-mail: sales@powbat.com
 Web page: www.powerbattery.com

CANADA
Power Battery (Iberville) Ltd.
 770 Thomas Ave.
 Iberville, Québec, J2X 5E7
 Phone: (450) 346-3273
 Fax: (450) 346-8003
 E-mail: powerbat@sympatico.ca
 Web page: www.powerbattery.com

UK
Power Batteries Ltd.
 Premier Way, Abbey Park Industrial Estate
 Romsey, Hampshire, SO51 9AQ
 Phone: +44 (0)1794 835900
 Fax: +44 (0)1794 835910
 E-mail: sales@powbat.co.uk
 Web page: www.powbat.co.uk

ITALY
Power Battery Srl
 Via Locatelli 105
 20046 Biassono MI - ITALY
 Phone: +(39) 039 2324571
 Fax: +(39) 349 2499200
 E-mail: calberti@powbat.it
 Web page: www.powbat.it