



**VALVE REGULATED  
LEAD ACID BATTERY (V.R.L.A.)**



**ADVANCED ABSORBED GLASS  
MAT TECHNOLOGY (A.G.M.)**



**LONG DURATION BATTERIES  
DESIGNED FOR MAXIMUM LIFE**



**10 VOLT CONFIGURATION AVAILABLE !**

### Features

- Flame-retardant polypropylene case and cover compliant with UL94 V-0 with an Oxygen Limiting Index of greater than 28%.
- Gas recombination greater than 99%.
- Operates at a low internal pressure.
- Never needs watering, minimal maintenance.
- 99.7% pure lead, calcium alloy grids.
- Shock absorbent thick wall polypropylene cases.
- Cold forged non-porous terminal bushings, eliminate post leakage.
- Thermally welded case to cover bond, eliminates both acid and electrical leaks.
- Over-sized, through the partition inter-cell welds provide low resistance connections, with minimal power loss.
- Flame arresting, low pressure safety release venting system for individual cells, recognized per U.L. 924.
- Measured high vacuum acid fill, reduces electrical variability between cells.
- 100% recyclable materials.

### Options

- Terminal covers.
- Inter-connecting battery cables.
- Custom wire harnesses.

### Specifications

Cells per unit	6
Nominal voltage	12
Terminal type	Threaded copper insert
Short circuit current	4982 amps
Impedance @ 77°F 25°C	2.77 milliohms
Weight lbs / kgs	99.4 / 45.1
Electrolyte (S.G.)	1.300
Capacity @ 77°F (25°C)	117 AH (8 hrs) to 1.75 V.P.C.
Ideal operating temperature range	+68°F (+20°C) to +77°F (+25°C)
Extended operating temperature range	Discharge: -40°F (-40°C) to +140°F (+60°C) Charge: -4°F (-20°C) to +122°F (+50°C)
Float Voltage	13.5 to 13.8 @ 77°F (25°C)
Recommended maximum charging current	C/4 amperes at 100% discharge Unlimited at partial discharge.
AC ripple from charging source	1.5% peak to peak of float
Storage period without recharge	6 months at 77°F (25°C)

### No transport restrictions

- Surface transport. Classified as non-hazardous material as relates to DOT-CFR Title 49 part 171-189.
- Maritime transport. Non hazardous as per IMDG amendment 27.
- Air transport. Non hazardous complies with IATA / ICAO, special provision A67.

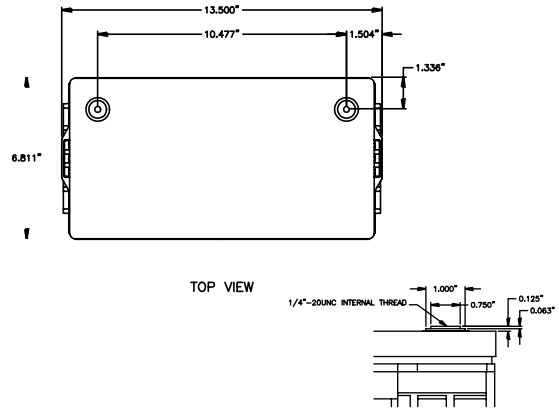
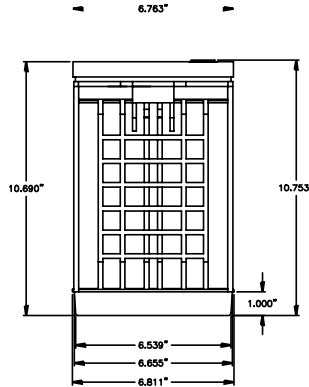
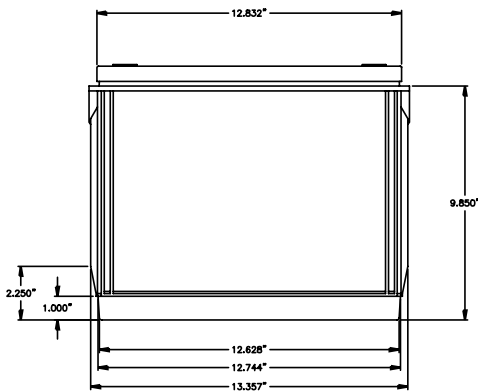

COPPER INSERTED TERMINAL DETAIL

POWER BATTERY offers an extensive line of pre-wired and fused battery cabinets complete with UL and CUL approval. Standard and custom DC voltages complete with breakers and chargers are available.

Battery Cabinet Systems (pre-wired with TL-12120 batteries)							
Battery cabinet model	Maximum # of batteries	Dimensions					
		inches			millimeters		
		H	W	D	H	W	D
KS5	2	15.75	15.0	25.0	400	381	635
KS6	4	17.75	16.0	34.5	451	406	876
KS7	8	37.25	16.0	34.5	946	406	876
CR1	12	43.0	24.0	32.5	1092	610	826
CR3	20	43.0	40.0	32.5	1092	1016	826
CR6	30	60.0	40.0	32.5	1524	1016	826
CR4	40	77.0	40.0	32.5	1956	1016	826

Hours discharge rates in constant current (Amperes) and constant power (Watts) @ 77°F (25C°)														
Volts per cell		I	2	3	4	5	6	7	8	9	10	12	24	48
1.75	Amps	81.3	47.2	34.4	27.0	22.2	18.9	16.5	14.7	13.1	12.0	10.2	5.50	2.96
	* Watts	965	581	422	335	280	241	211	188	169	154	130	68.7	37.7
1.80	Amps	80.1	46.9	34.0	26.5	21.9	18.6	16.3	14.5	13.0	11.9	10.1	5.40	2.29
	* Watts	953	561	409	326	272	233	203	180	162	147	124	66.5	36.2
1.85	Amps	76.9	45.4	32.8	25.6	21.1	18.1	15.7	14.0	12.6	11.5	9.70	5.20	2.70
	* Watts	922	540	393	312	260	223	194	173	156	141	120	64.0	33.9
1.90	Amps	70.7	42.5	30.8	24.2	19.9	17.0	14.8	13.0	11.7	10.6	8.90	4.80	2.55
	* Watts	866	500	362	288	242	209	184	166	148	135	114	61.2	32.6

\* For 10 Volt models reduce the Watts by 18%

**U.S.A.**  
**Power Battery Company, Inc.**  
 25 McLean Blvd.  
 Paterson, N.J. 07514-1507  
 Phone: (973) 523-8630  
 Fax: (973) 523-3023  
 E-mail: sales@powbat.com  
 Web page: www.powerbattery.com

**CANADA**  
**Power Battery (Iberville) Ltd.**  
 770 Thomas Ave.  
 Iberville, Québec, J2X 5E7  
 Phone: (450) 346-3273  
 Fax: (450) 346-8003  
 E-mail: powerbat@sympatico.ca  
 Web page: www.powerbattery.com

**UK**  
**Power Batteries Ltd.**  
 Premier Way, Abbey Park Industrial Estate  
 Romsey, Hampshire, SO51 9AQ  
 Phone: +44 (0)1794 835900  
 Fax: +44 (0)1794 835910  
 E-mail: sales@powbat.co.uk  
 Web page: www.powbat.co.uk

**ITALY**  
**Power Battery Srl**  
 Via Locatelli 105  
 20046 Biassono MI - ITALY  
 Phone: +(39) 039 2324571  
 Fax: +(39) 349 2499200  
 E-mail: calberti@powbat.it  
 Web page: www.powbat.it