

FRONT ACCESS



**VALVE REGULATED
LEAD ACID BATTERY (V.R.L.A.)**



**ADVANCED ABSORBED GLASS
MAT TECHNOLOGY (A.G.M.)**



**LONG DURATION BATTERIES
DESIGNED FOR MAXIMUM LIFE**



The FT series of batteries are ideal for installations where space is at a premium. The front access design permits rapid installation and reduced maintenance time.

Features and Benefits

- Ten year design life in telecom float service.
- A recognized component of U.L.
- Valve regulated lead acid battery (VRLA).
- Absorbed glass mat technology (AGM) with gas recombination greater than 99%.
- Operates at a low internal pressure.
- Never needs watering; minimal maintenance.
- Shock absorbent thick wall construction.
- Advanced lead tin calcium alloy, reduces grid corrosion and promotes long battery life.
- Flame-retardant ABS plastic case and cover compliant with U.L.1778 V-0 with an Oxygen Limiting Index of greater than 28%.
- Cold forged nonporous terminal bushings; eliminate post leakage.
- Thermally welded case to cover bond; eliminates both acid and electrical leaks.
- Over-sized, through the partition inter-cell welds for minimal power loss.
- Flame arresting, low pressure safety release venting system for individual cells, recognized per U.L. 924.
- Measured high vacuum acid fill, reduces electrical variability between cells.
- Terminal and bussbar covers.

Options

- Custom wire harnesses.
- 10 volt version.
- High temperature retaining sleeves.

Specifications

Cells / Volts	6 cells / 12 volts
Terminal type	Threaded copper insert, 1/4"
Capacity @ 77°F (25°C)	155 AH (8 hrs) to 1.75 V.P.C.
Operating temperature range:	-40°C/-40°F to 60°C/140°F
Charging voltage / current:	2.27 to 2.30 volts per cell, constant voltage at a maximum current of C/4 amps.
Temperature compensation: Apply for temperature range of 0°C/32°F to 40°C/104°F.	Subtract 3mV/°C/cell or 1.7 mV/°F/cell, above 25°C/77°F. Add 3 mV/°C/cell or 1.7 mV/°F/cell, below 25°C/77°F.
Storage time from a fully charged condition:	6 months at 25°C/77°F. For each 9°C/15°F rise, reduce the storage time by half.
Self discharge rate	Less than 2% per month @ 25°C/77°F
AC ripple from charging source	1.5% peak to peak of float
Overall dimensions (inches, mm)	11.81" H x 21.96" L x 4.86" W 300mm H x 558mm L x 123mm W
Weight	135 lbs / 61.2 kgs

Standards and Compliances

- UL Compliant
- NEBS Compliant
- EUROBAT,
10 year plus classification
- Tested in accordance with
 - BS6290 PART 4, 1987
 - Bellcore, TR-NWT-000766
 - ANSI, TI: 330

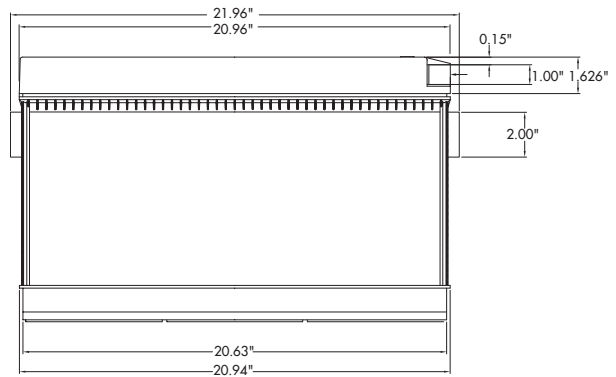
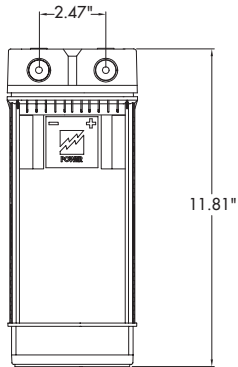
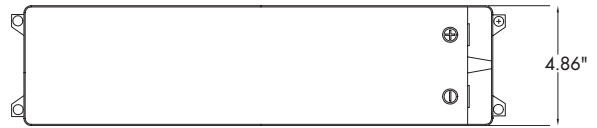

Hourly Discharge Rates in Amperes @ 77°F (25C°)

Discharge Hours	End Voltage Per Cell				
	1.95V	1.90V	1.85V	1.80V	1.75V
1	76.00	87.00	96.00	103.00	105.00
1.5	55.00	66.00	70.14	73.06	74.16
2	48.00	54.00	58.45	60.89	61.80
3	34.00	39.00	41.40	43.13	43.78
4	27.00	30.44	33.12	34.50	35.02
5	22.00	25.00	27.28	28.41	28.84
6	18.86	21.93	23.87	24.86	25.24
7	16.45	19.13	20.81	21.68	22.00
8	14.60	16.85	18.33	19.09	19.38
9	13.20	15.35	16.71	17.40	17.66
10	12.00	13.95	15.18	15.81	16.05
11	11.01	12.81	13.94	14.52	14.74
12	10.11	11.76	12.79	13.33	13.53
15	8.19	9.52	10.36	10.79	10.95
20	6.30	7.33	7.97	8.30	8.43
24	5.30	6.16	6.70	6.98	7.09

Rates subject to change without notice.