

UNINTERRUPTIBLE POWER SUPPLY



3 Year
Warranty

G9000 Series

80/100/160/225 KVA UPS



**All IGBT
Design
96.5%*
Efficiency**

- Next-Generation IGBT Technology
- True On-Line, Double-Conversion UPS
- Parallel up to Four Units
- Input Power Factor > 0.99
- Input Current THD < 3%
- Output Power Factor 0.9
- 100% Unbalanced Load Capability
- Wide Input Voltage Range +15%, -20% (Without Utilizing Batteries)
- High Efficiency for Lower Operational Cost
- Smallest Footprint and Highest Power Density in Industry
- Electronic Battery Isolation for Battery Longevity
- Generator-Friendly Design and Compatibility
- Complete Front-Access for Installation, Operation, and Service
- Matching Battery Cabinet for Customized Battery Backup Time
- SNMP/Web-Based Monitoring
- Three-Year Warranty for Lower Cost of Ownership

*See specifications on back.

Reliability in motion[®]

G9000 Series 80/100/160/225 KVA UPS

Model Number		T90S3S08KS6XSN	T90S3S10KS6XSN	T90S3S16KS6XSN	T90S3S22KS6XSN
Capacity	KVA/KW	80/72	100/90	160/144	225/202.5
Topology	True On-Line, Double Conversion, Advanced Multi-Level IGBT Technology				
Input	Voltage	480 V, Three-Phase, Three-Wire + Ground/Bypass Input, 480 V, Three-Phase, Three-Wire + Ground			
	Voltage Range	480 V, -20% to +15% (384 to 552 V Without Utilizing Battery)			
	Power Factor	Greater than 0.99			
	Current THD	<3% at 100% Load (No Input Filter Required)			
	Frequency	60 Hz (± 10%)			
Output	Voltage	480 V, Three-Phase, Three-Wire + Ground			
	Frequency	60 Hz, ±0.01% (In Free-Running Mode)			
	Voltage Regulation	±1.0% (0.5% Typical)			
	Power Factor	0.9 Lagging			
	Power Factor Range	0.9 to 1.0 Lagging			
	Voltage THD	<2% for Linear Load, <5% for Non-Linear Load			
	Overload (Inverter)	125% for 2 Minutes; 150% for 60 Seconds			
	Overload (Bypass)	1000% for One Cycle			
Battery	DC Link	480 VDC			
	Ripple Voltage	±0.23%			±0.29%
Environment	Temperature Range	32° to 104°F (0° to 40°C)			
	Relative Humidity	5% to 95% Non-Condensing			
	Heat Rejection	11,307 BTUs/Hour	14,133 BTUs/Hour	19,408 BTUs/Hour	27,292 BTUs/Hour
	Efficiency (Full-Load)	95.6%	95.6%	96.5%	96.5%
	Efficiency (20% Load)	92.5%	92.5%	94.6%	94.7%
	Altitude	7380 Feet Maximum Without Derating (2250 Meters)			
Dimensions	Dimensions (W x D x H)	27.6 x 32.8 x 80.6 in. (700 x 832 x 2047 mm)		35.4 x 32.8 x 80.6 in. (900 x 832 x 2047 mm)	
	Weight	835 lbs. (388 kg)	855 lbs. (388 kg)	1160 lbs. (526 kg)	1230 lbs. (558 kg)
Features	Digital Signal Processor (DSP) Control, Fully Digital IGBT Converter & Inverter, High Efficiency Over Wide Load Range, Transformer-Less Design, N+1 and N+N (Up to Four in Parallel) Capability, Dual-Input Feed, Electronic Battery Isolation, RS232 and Dry Contact Interface, Small Footprint, Lightweight Design				
Standards	UL 1778, CUL, ISO9001, ISO14001, ANSI C62.41 (IEEE 587), FCC Class A, Article 47, Part 15.B				
Warranty	Three Years Onsite (Optional Two Year Extended Warranty) See Toshiba Warranty Policy for Full Details				
Service	24-Hour, 365-Day Technical Support 1-877-867-8773				

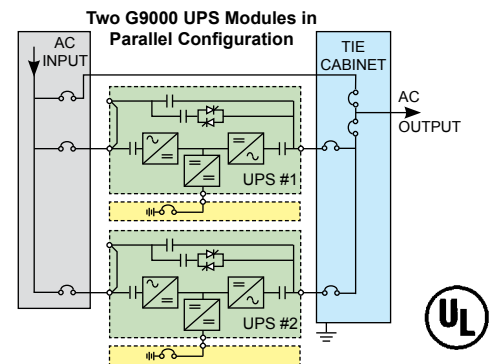
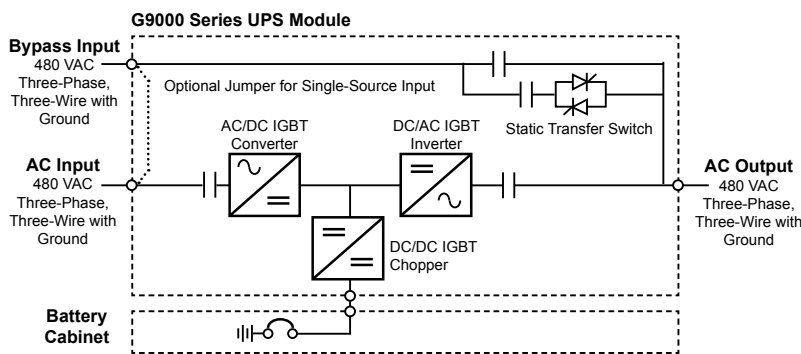

UPS ADJUSTABLE SPEED DRIVES MOTORS CONTROLS INSTRUMENTATION PLC

TOSHIBA

Available Through:

TOSHIBA INTERNATIONAL CORPORATION

INDUSTRIAL DIVISION

13131 West Little York Road, Houston, Texas 77041

Tel 713/466-0277 Fax 713/466-8773

US 800/231-1412 Canada 800/872-2192 Mexico 001/800/527-1204

www.toshiba.com/ind

Copyright 12/2008 UPS G9000 B05 23 08-001

