

**TOSHIBA**

## UNINTERRUPTIBLE POWER SYSTEMS



**XT**

# 1600EP Series

3.6 to 22kVA Single Phase

**3** Year  
Warranty

- True On-Line, Double Conversion UPS
- Input Power Factor > 0.95
- Input Current THD < 5%
- Wide Input Voltage Window +10% to -30%
- Wide Input Frequency Window 45 to 65 Hz
- 0.85 Output Power Factor; More Usable Watts per kVA
- Electronic Power Factor Correction for 100% Generator Compatibility
- Hot-Swappable Battery Packs & Cooling Fans
- Internal Isolation Transformer
- Digital LCD Display
- Programmable Front Keypad
- External Battery Connector

**Reliability *in motion***<sup>®</sup>

# 1600EP Series 3.6 to 22 kVA UPS

Capacity	3.6 kVA (3.06 kW)	6 kVA (5.1 kW)	8 kVA (6.8 kW)	10 kVA (8.5 kW)	14 kVA (11.9 kW)	18 kVA (15.3 kW)	22 kVA (18.7 kW)
Topology	True On-line; Double Conversion; IGBT Power Factor Corrected Input; Internal Isolation Transformer						
Certifications	UL 1778, CUL, CE, FCC Class A, IEEE 587, ANSI / C62.41, ISO 9001, ISO 14001, NEMA / PE1-1993						
<b>Input Characteristics</b>							
Input Voltage	Single-Phase 208/240 Vac (3 Wire Input/L-L,G); 230 Vac (3 Wire Input / L, N, G), +10% -30%						
Input Frequency	45 to 65 Hz (Auto-Sensing)						
Input Power Factor	> 0.95 For All Loads						
Input Current THD	< 5% (Even for 100% Non-Linear Loads)						
AC Input Breaker Rating	30 A	50 A	60 A	60 A	100 A	100 A	125 A
<b>Battery Characteristics</b>							
Battery Type	Valve Regulated Lead Acid; Flame Retardant (9.0 Amp Hr)						
Backup Time (Fully Charged)	14 Minutes	7 Minutes	7 Minutes	5 Minutes	7 Minutes	5 Minutes	3 Minutes
	0.85 Power Factor; 77° F; Approximately 30% More Runtime for Output Power Factor of 0.7 (Triple Backup Time at ½ Load)						
Recharge Time	24 Hours (Full), 12 Hours (90%)						
DC Link	216 VDC			288 VDC			
<b>Output Characteristics</b>							
Output Voltage	Single-Phase 240/208/120 Vac (4 wire Output/L-L, N, G) 230 Vac (3 Wire Output L, N, G)						
Output Voltage Regulation	+/- 3 Max.; +/- 1% Typical						
Output Frequency	50/60 Hz; +/- 0.5 Hz/1.5 Hz (Factory or Authorized Service Center Selectable.)						
Output Voltage THD	< 3% for Linear Load; 1% Typical						
Common Mode Noise	< 0.5 V Peak						
Rated Load Power Factor	0.85 (0.6 to 1.0) Lag						
Efficiency (ac-dc-ac)	> than 85%						
Rated Output Current @ 240 V	15 A	25 A	33.3 A	42 A	58 A	75 A	91 A
Max. Peak Output Current	45 A	75 A	100 A	126 A	174 A	225 A	273 A
Overload Capacity	150% for 10 Seconds and 125% for 10 Minutes; Bypass: 1000% for 1 Cycle						
Heat Generation (BTU/Hr)	1588	2610	3482	4352	6092	7832	9600
<b>Mechanical Design</b>							
Enclosure	Enclosure of Unit Made from Steel; Complies with NEMA 1 and UL Type 1 Standard						
Enclosure Dimensions (L x W x D)	27.5" x 10" x 33"		28.25" x 13" x 33.5"		39.1" x 17.5" x 34.8"		
Shipping Weight	365 lbs/166 kg	385 lbs/175 kg	490 lbs/222 kg		620 lbs/281 kg	750 lbs/340 kg	755 lbs/343 kg
Battery Pack Size (L x W x D)	5" x 7.3" x 18.2" (6 Batteries of NPX-35 Per Pack)						
Battery Pack Quantity	3			4		8	
<b>Options</b>							
RemotEyeII	SNMP & WEB Based Monitoring, Internal and External Modules Available						
Matching Battery Cabinet	Consult Factory						
Internal / Ext. Maintenance Bypass	Consult Factory						
Receptacle Panel & Line Cord	Consult Factory						
<b>Warranty</b>	<b>3 Years on Electronics (UPS); 2 Years on Battery (See Toshiba Warranty Policy for Full Details)</b>						

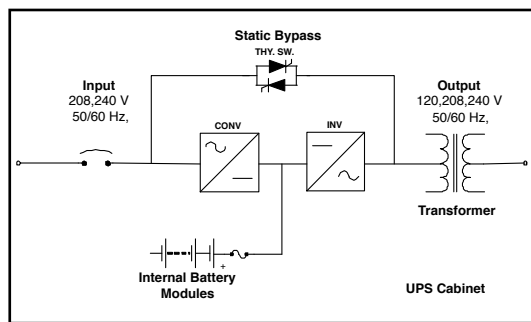

RemotEye II®  
(Option)

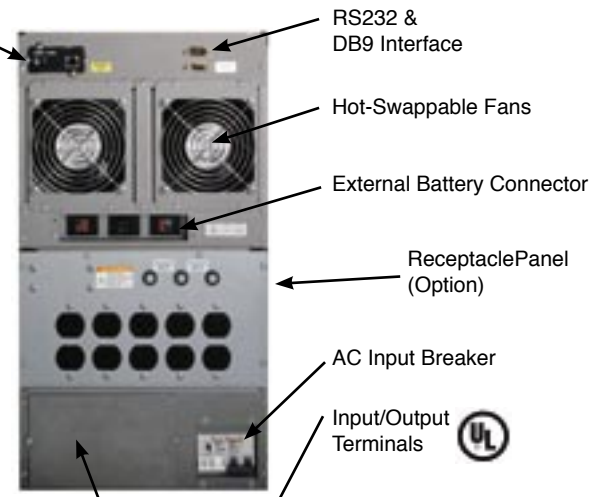

**UPS    ADJUSTABLE SPEED DRIVES    MOTORS    CONTROLS    INSTRUMENTATION    PLC**

# TOSHIBA

TOSHIBA INTERNATIONAL CORPORATION

**INDUSTRIAL DIVISION**

13131 West Little York Road, Houston, Texas 77041

Tel 713/466-0277 Fax 713/466-8773

US 800/231-1412 Canada 800/872-2192 Mexico 001/800/527-1204

www.toshiba.com/ind

Copyright 11/2006

Available Through:

